

2019

History of Maine - Logging

Wood Splitters Direct

Follow this and additional works at: <https://digitalcommons.library.umaine.edu/mainehistory>



Part of the [History Commons](#)

Repository Citation

Direct, Wood Splitters, "History of Maine - Logging" (2019). *Maine History Documents*. 222.
<https://digitalcommons.library.umaine.edu/mainehistory/222>

This Other is brought to you for free and open access by DigitalCommons@UMaine. It has been accepted for inclusion in Maine History Documents by an authorized administrator of DigitalCommons@UMaine. For more information, please contact um.library.technical.services@maine.edu.



Orders or Questions?
Call Us Toll Free at
888-706-2434



YOU ARE HERE: [Home](#) > [Blog](#) > A History of Maine Logging

A History of Maine Logging



MAINE: "THE PINE TREE STATE"

Maine, known fondly as "*The Pine Tree State*" has a long, rich history of logging. Before gaining its statehood in 1820, Maine was part of the Massachusetts territory and was involved in the lumber trade with England. In the early days, beautiful **pin**es were harvested from Maine's forests to supply masts for England's navy. Settlers to the region also used wood to build homes and other buildings in their settlements. Logging is still a thriving industry in this beautiful state today, particularly in the northern regions.

GENERAL MAINE LOGGING

Maine's logging history began in the **early 17th century** when English explorers first cut trees on Monhegan Island. Maine's *first official sawmill* was built in 1634 in the small town of South Berwick. Fifty years later, the Maine region had 24 fully operational sawmills, shipping primarily soft wood (pine). **Softwood** was easier to float down streams during the spring floods.

During these early days of logging, England demanded the best lumber to build **masts** for their naval ships. The English had already depleted their country's sources of wood and had run out of viable lumber trading options with other nations. The New World had seemingly unending lumber resources that England was eager to exploit.

The Act of 1729, passed by England, reserved to the Crown all pines measuring 24 or more inches in diameter, at least 12 inches above the ground. Unfortunately, the vast majority of land in the Maine region was public, so the Crown marked an alarming number of trees.

Colonists who relied on lumbering to make money were angered that so many of the good trees were marked for the crown. They were unable to use these trees for their settlements, so resentment toward the Crown grew quickly. The tree marking would be one of the *major grievances* against England in the American Revolution.

In 1762, many of the trees that were felled to supply England with ship masts received damage during the log drives or were deemed unsuitable for masts for any number of reasons. A large amount of this lumber was discarded because of the damage. But 14 years later, the American colonies declared their independence from England, bringing an end to the obligatory mast lumber trade.

Up until 1820, logging in New England was done in one of three ways: independent, family-operated, or through a partnership. **Logging cooperatives** became common the same year that Maine received its statehood, **1820**. The era between 1820 and 1880 is known as the era of cooperation, led primarily by lumbermen associations.

Unfortunately, the ordinary logger didn't profit much from his incredibly difficult and dangerous labors. The majority of profits from the lumber industry filled the pockets of lumber barons and company owners across New England.

Despite the hardships and poor pay, loggers helped create a *booming industry*. By 1830, **Bangor, Maine**, was the world's largest lumber shipping port. Between 1830 and 1890, 9.7 trillion board feet of timber was moved through Bangor. By 1834, the lumber industry had made Bangor a boom town. The population exploded from 2,800 to 8,000 people between 1830 and 1834, and many of the jobs were in the lumber mills.

During the winter months, Maine's woods were filled with **logging camps**. Axes, and later saws, were used to harvest a number of different trees for specific purposes. *Pine* and *oak* were used for shipbuilding, *cedar* was used for shingle, *hemlock* for tanning, and *spruce* and *fir* were used for pulp to make paper.

The **winter** months were cold and bitter, but they were ideal for log cutting because the snow and frozen lakes/streams provided easy movement of logs. Horses and oxen could drag the logs without fear of snagging. Logs could then be stacked

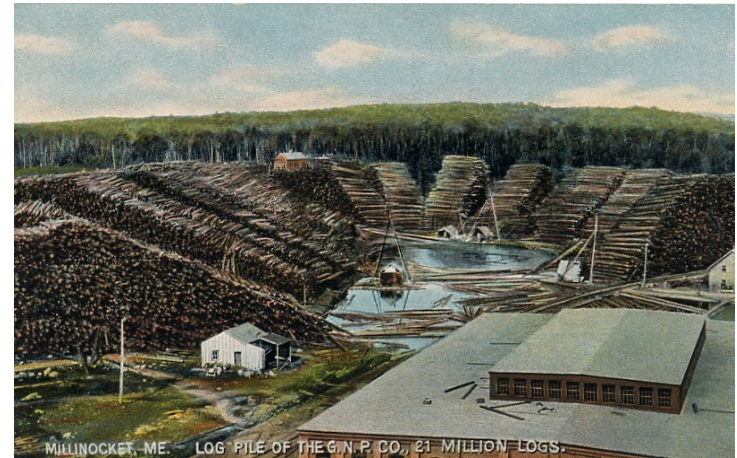

onto river banks, ready to be pushed into the swollen spring rivers for the annual spring log drives. Of course, spring log drives were ideal because the high water levels helped prevent log jams and snags.

Because river's made transporting logs from the forests to the mills relatively easy, Maine's lumber industry grew up around the Androscoggin, Kennebec, and Penobscot Rivers. Tributary streams were also used to transport logs to these major waterways.

The national demand for lumber continued to increase throughout the 19th century, so lumber industry positions expanded and large tracts of forest were cut away. Positions included *surveyors* to identify profitable stands of trees, *lumbermen* to cut timber, *teamsters* and *draft animals* to haul cut logs, *scalers* to measure the timber's worth, and *river drivers* to float logs to the mills.

Many lumbermen also worked as river drivers. The toll logging took on Maine's forests was recorded by Henry David Thoreau, who remarked on the number of stumps "as high as one's head" that he found during his time spent in the woods. Because lumbermen were working during the winter, snow covered the bottom parts of the trees.

In 1840, the majority of sawmills in Maine were concentrated in Bangor, Orono, Old Town, Milford, and Bradley. The small community of **Patten** was also a major center for logging operations along the Penobscot River. Today this town has a really cool logging museum. Some sources say that Maine's booming lumber days ended in the 1880s when readily accessible

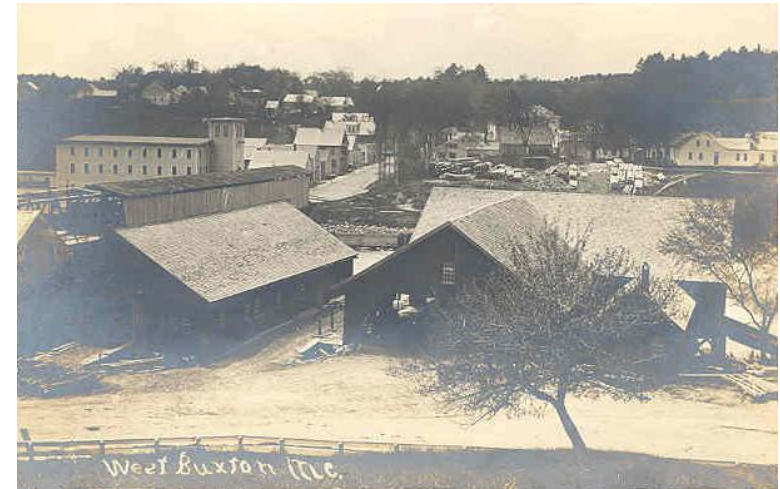

timber had disappeared. Logging was still an important part of Maine's economy, but as logging moved west, many of Maine's boom towns faded.

Logging was mechanized in the 20th century and specific species of trees were overharvested in record times. Maine was trying to compete with logging companies in Canada and the northwest. Regulations passed later in the 20th century have reversed deforestation effects, and Maine's current logging industry is dedicated to sustainability.

LIVING IN THE LOGGING CAMPS

Life in the logging camps was difficult. Food choices were rarely diverse and the bunkhouses, though warm, gave off pungent odors and were rarely clean.

Logging camps did not become a regular thing until major lumber companies entered the scene. Loggers would live in the camps for *4 to 5 months* during the logging season (all through the winter). In the beginning (1820s), logging camps were actually **one building** (20×20) built around a fire pit that supplied both warmth and a means of cooking. Twelve to fourteen men would live in the camp. They generally had a team of oxen to help transport logs.

These initial camps were constructed with spruce logs for the walls – cracks were filled with moss to keep the heat in – and cedar shingle roofs. The men had to share one big communal bed. The mattress was just a bed of balsam fir shavings, and the men had to share one big blanket.



Men washed in the “sink” – a hollowed log filled with water. And since the fire was located inside the “camp” men would hang their wet clothes and socks by the fire, creating a pungent aroma throughout the small building.

In later years, camps split into **two buildings**: a cookhouse and bunkhouse. These were called “double camps.” And often the boss would have a separate cabin for himself. At the beginning of the 20th century, logging was centered around pulpwood for paper, and logging camps had better conditions (though still poor compared to today’s standards).

A 1920s-era camp offered less than 20 square feet of sleeping space for the lumbermen. None of the bunks had mattresses and few had pillows. The bunks were full of hay or straw and men could add more if needed – and if they could find it. Men had access to blankets (spreads), but no sheets. The spreads were supposed to be *washed once a year* – if you can call being dunked into hot soapy water a wash – but sometimes the annual washing was forgotten.

Modern logging camps have usual household amenities with nice bunkhouses and real mattresses. There aren’t very many logging camps left in Maine, but the ones that are left offer a second home and family for lumbermen. (One of the most notable modern camps is **Comstock Camp** in Northern Maine.)

The Cooks and The Food

Robert E. Pike wrote in *Tall Trees, Rough Men* (1967) that woodmen would not work well unless they were well fed, so camp cooks carried a lot of weight and respect – if they were good. Records show that many cooks demanded absolute silence during meals to speed the men’s eating process and allow ample time for clean-up.

Well-respected cooks could threaten to leave the camp if they felt they were being treated unfairly. A camp with no cook or a bad cook would have a hard time surviving the season.

A **good cook** was characterized by his or her ability to “prepare one thing in a number of different ways” according to Richard Judd, author of *Aroostook: A Century of Logging in Northern Maine*. Ingredients were severely limited because there was no refrigeration. Some **staples** of every Maine logging camp were: salted meats, salted or canned fish, pork and beans, molasses, gingerbread, and tea. Hardly a nutritious diet.

Records say that during the logging season, a camp of fifty men would “consume a barrel of flour each, sixty bushels of beans, two hundred bushels of potatoes, seven hundred pounds of ole margarine, one hundred pounds of tea, and a vast amount of meat and fish.”

(<http://www.greatnorthwoods.org/logging/cliftonjohnson/2.htm>)

As camps grew larger, cooks gained more assistants, called cookees. Cookees had to help clean, build fires, and deliver meals to loggers who were too far from the camp to return for the noon day meal. During the beginning of the season, lumbermen established their seats for the evening meal. If new men came to the camp they would have to wait until every man was seated before he could choose his official seat.

Camp Visitors

Around 1900, visitors to logging camps included peddlers or people from mountain villages on some sort of business. Occasionally a priest or missionary would come on Sunday to hold a service.



Peddlers who sold their wares were given payment in the form of orders on the boss, who deducted 10% of the sale for his share in the transaction.

A LOGGER'S LIFE

When logging companies were established, many men came down from Canada to work for a season. The men were usually very **young** and seldom worked for more than two or three seasons. Some historians theorize that the French Canadians who worked in Maine's forests were trying to pay off farms that they had purchased.

After a couple of seasons, their farms would be paid off and they could work on the farm year round. Around 1900, lumbermen made between 17 and 30 dollars a month depending on their individual ability and work performed. Scots and Irish men also made up a large majority of lumbermen.

Loggers often worked from sunup to sundown, either cutting timber or driving logs down river. The work has always been **dangerous**. The men had to constantly be aware of their surroundings to avoid being smashed by a falling tree or falling off a log into an icy, raging river. Many river drivers did not know how to swim.

Losing one's balance while trying to break up a log jam could mean death. Luckily, caulk boots (spiked) helped the river drivers balance. Dynamite and special tools were used to break up log jams along the river until log drives were banned in



the 1970s.

Literature from the early 20th century romanticizes lumbermen and log drivers. Fanny Hardy Eckstorm, wrote a beautiful description of log drivers breaking up log jams along the Penobscot River in her book, *The Penobscot Man*.

SCALERS – ORIGINS AND ISSUES

William S. Warner gives an amazing account of the scaler in his essay "[The Scaler: Forgotten Man in Maine's Lumbering Tradition](#)." I will give a brief account of who the lumber scalers were and the role they played in Maine's lumber history.

A **scaler** is someone who measured standing timber, logs, and sawn lumber at the mills. They were also known as **surveyors** in the early 19th century. The position of the scaler grew as lumber cooperatives grew and the forest industry became more complex. Warner says scalers were often thought of as "educated men who made more money, did less work, and lacked the daredevil attitude of loggers." However, the scaler measured the success of the season, so logging companies were highly dependent on them.

In 1783, Massachusetts law required each town to annually elect a scaler (known then as a surveyor) to grade and measure products. All products had to be measured before sale. When logging cooperatives were established, the number of scaling jobs increased, including both elected surveyors and private scalers.

As pine tree forests were thinned out, the need for accurate measurements increased. Scaling methods had to be refined, and by the end of the 19th century, scaling was a "significant element in the success of the season's operation."

In 1821, a Maine law **authorized fees** for scalers. They had to be paid eight cents per thousand lineal feet for “viewing and inspecting” and an additional three cents for measuring and marking the quality of the wood. This, unfortunately, led to quite a bit of lying from scalers, who wanted to make more money.

Not many years later, in 1833, the fees doubled. During this time, scalers were also required to mark all the lumber they measured with the lineal feet. This was an effort to keep the scalers honest, although it did not always work. Scalers were also required to turn over 1/10 of their earnings to the surveyor-general.



At the same time that public scalers were earning 16 cents per thousand lineal feet, **private scalers** were only earning four to five cents per thousand lineal feet. Most private scalers worked in the logging camps, measuring unfelled timber and cut lumber at river landings. In contrast, public scalers worked in the mills in large cities. Their job was to measure felled/cut timber before products could be sold.

The scaler, even if he was an honest one, was generally distrusted by everyone he worked with. He had the unfortunate job of liasoning between the lumbermen and the logging boss. Both parties often felt cheated by the scaler. This distrust gave scalers low social status in the camps, although they often got to bunk with the boss. Another reason for their low social status may have been their lack of participation at evening meals. They would be busy working with numbers alone in their bunk.

Honest scalers were incredible assets to their companies. One unknown scaler invented the **bucking board**, an incredible incentive for lumbermen. The bucking board was just a piece of paper hung on the door of the men's bunk listing the amount of wood each teamster had hauled for the day or week. Bucking boards encouraged competition among the men, although sometimes this led to arguments over the fairness of the scale. Unfortunately for the teamsters, their extra efforts didn't earn them extra money, just pride.

It wasn't until the end of the 19th century that actual measuring standards were set for scalers. Prior to this scalers had been making educated guesses on the profits to be made for certain sizes of logs and lumber. A good scaler would have a sharp mathematical mind and an eye for crooked or defective wood.

One of the measuring standards was called a **log rule**. The log rule was a table or formula that showed an estimate net yield for logs of a given diameter and length. The yield was often expressed in terms of cords, board feet, or cubic feet of finished lumber. The results were converted to a scale and printed on measuring sticks that were then applied to the logs.

Even though measuring standards had been established, there was no nationwide standard for scalers. By 1906, there were 45 recognized rules in the United States and Canada.

LOG DRIVES

Once wood had been scaled at the camp, it was moved to the river landing to await the thawing of the river. In the **spring**, logs were driven down the river to the "booms" or mills for sorting. Unfortunately, there was lumber from a variety of companies floating down the river at any given time. So in order to avoid conflict, lumbermen formed **mutual benefit**

companies to coordinate driving, sorting, and rafting activities. One example of these companies is The Penobscot Log Driving Company (PLDC).



PLDC delivered the logs of all operations along the Penobscot River into various booms. Each operator was charged a fee for the number of board feet he put through the boom each season. Scalers would measure the lumber at the boom. Logs had to be sorted and grouped in the middle of the river near the booms to determine the fee each operator had to pay.

Booms were built by millowners along the major rivers as the last stop for lumber. Lumber was counted, sorted, and distributed at these booms.

Log drives down the great Maine rivers were banned in the 1970s because of the pollution they caused. However, some tributary springs show remnants of logging sluices and dams used to move lumber to the mills.

For a visual of the exciting log drives, watch the short, silent film [Logging in Maine](#). This 1906 film follows a log drive and team of river drivers.

HASTINGS – A LOST LUMBER COMMUNITY

Hastings is a great example of a **logging community** near the end of the 19th century. It was a major logging center from 1890 to 1910 and was completely abandoned in 1918.

In 1851, David Robinson Hastings purchased several hundred acres of land in the White Mountains, including land that would later become Hastings village.

The Hastings' brothers bought land around the same area. His brother, Gideon, built a farm and worked to improve the logging road to the railroad station at Gilead. By the mid 1880s, Hastings was harvesting thousands of cords of hemlock bark to tanneries in Maine. He was also cutting vast quantities of virgin spruce for lumber.

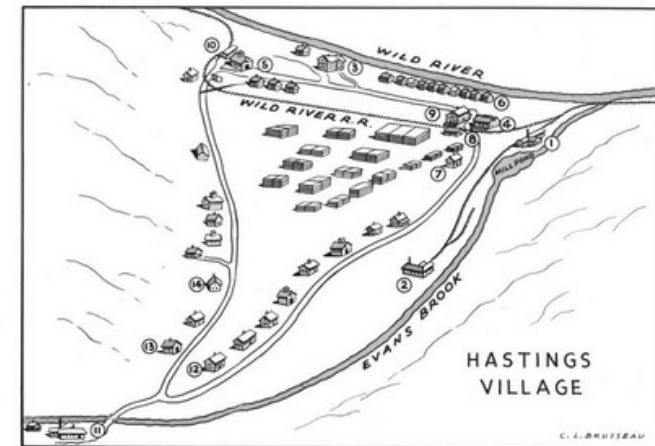

1. Wild River Lumber Co.: Saw Mill, 2. Wood Alcohol Mill, 3. Boarding House, 4. Freight Shed, 5. Barn, 6. Cottages (Ten Commandments), 7. School House, 8. Office, 9. Store, 10. Freight Shed; 11. Hastings: Birch Mill, 12. Boarding House, 13. Blacksmith Shop, 14. Store.

Despite the Hastings brothers involvement in the White Mountains, Hastings village was actually developed by **Samuel D. Hobson**. He helped form the Wild River Lumber Company for cutting, manufacturing, selling and dealing in lumber and other forest products. Hastings village grew up around the company. At its peak it boasted 300 year-round residents, but with the addition of seasonal woodsmen, the area was home to over 1000.

Hobson also helped in the construction of the **Wild River Railroad**. This railroad was the only way of reaching the timber stands near the headwaters of Wild River from the Grand Trunk Railway in Gilead – a distance of 14 miles. It was in full operation from 1891 to 1904.

Foreseeing the end of a profitable market, Hobson sold the company to Daniel Emery, a native of Portland, in 1898. Emery changed the company name to **Hastings Lumber Company**. Production increased dramatically to 65,000 board feet per day, and the railroad was pushed to its limits. Raging forest fires in 1903 destroyed large tracts of forest and a major part of the rail line. Operations at the Hastings Lumber Company officially ended in the fall of 1904.

The sawmill at Hastings village continued to operate sporadically under the Hastings family until 1910. By 1918, the village was completely abandoned. It has been totally incorporated back into the forest, but explorers with keen eyes may find remnants of the once prosperous lumber village.

FAMOUS LOGGING EQUIPMENT

Both the steam **Lombard log hauler** and the widely used “peavy” were invented in Maine. The steam Lombard log hauler was the first successful tracked vehicle. It was patented in 1901 by Alvin Lombard of Waterville, Maine.

The log hauler travelled on icy roads at a maximum speed of 5 mph. But the best thing about the log hauler was that it could tow multiple sleds of logs with loads up to 300 tons, replacing the work of 50 horses! Eventually the machines switched to gasoline power.

The well-known **peavy** was invented in 1858 by Joseph Peavey, a Maine native and blacksmith at Stillwater near Old Town. He created the peavy to “improve the work of the river drivers as they attempted to move and separate logs heading to a sawmill.” A pick and hook were added to the end of the peavy to help turn logs and control them down the river.



UNDERWATER LOGGING – MAINE TODAY

Logging still takes place in many forms throughout Maine. One of the most interesting forms of logging in the region, however, is underwater logging. **Dead Head Lumber**, operated by Todd Morrisette, scours lake floors across Maine for abandoned logs.

Morrisette believes that most of the logs he recovers were cut around the 1830s and after during the major boom. The logs, for whatever reason, sank during log drives. Because Maine’s weather out on major lakes can become unpredictable, these logs were abandoned by river drivers. They have been preserved for nearly 200 years by Maine’s fresh water and lack of oxygen.

Most of these logs are used to create wood floors and kitchen tables throughout Maine.

Museums to Visit

Maine Forest and Logging Museum

Patten Lumbermen's Museum

Boom House Museum

Maine Forestry Museum

Bangor Museum and Center for History

Resources to View

Living off the Land & Sea

A Logging Camp c. 1900

Old Boy, Did you get enough pie? A Social History of Food in Logging Camps

Photo Credits

http://whitemountainhistory.org/Hastings_Maine.ht...

<http://www.greatnorthwoods.org/logging/cliftonjohnson/2.htm>

 Share this post



FOLLOW US



JOIN OUR NEWSLETTER

BEST-SELLING PRODUCTS

HOT

SALE

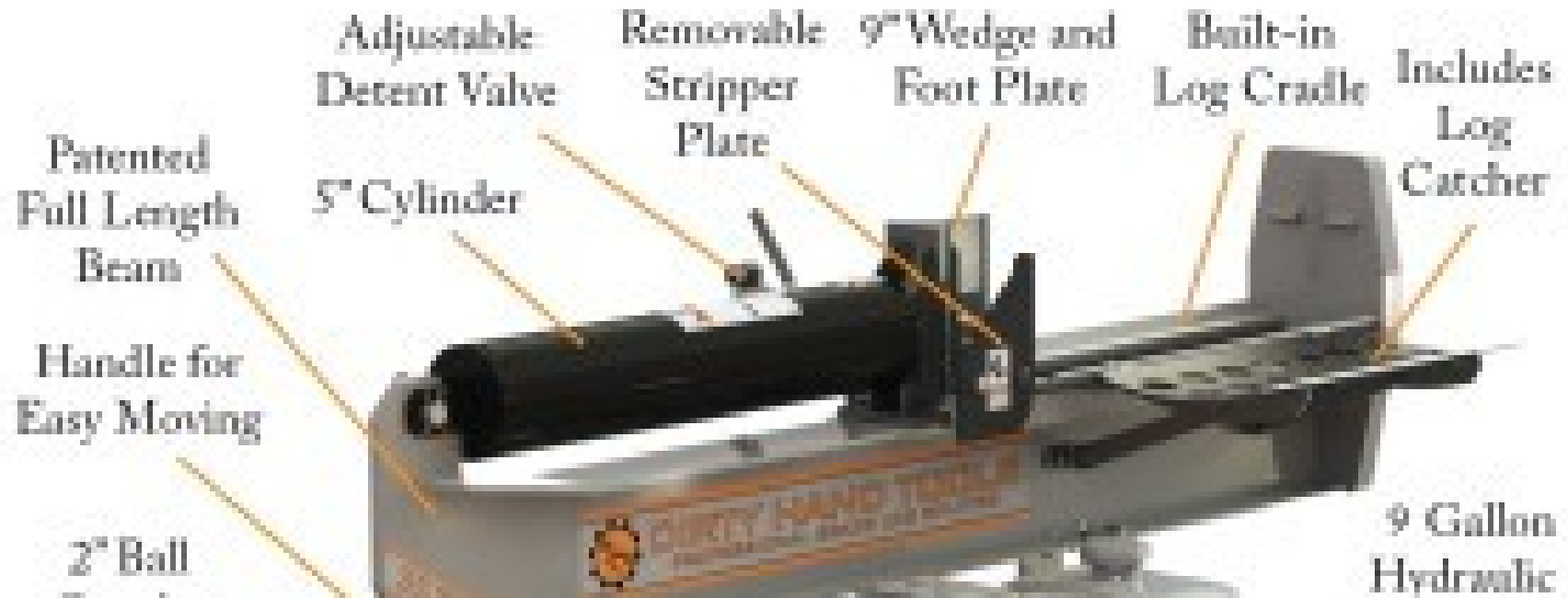

Coupler

System

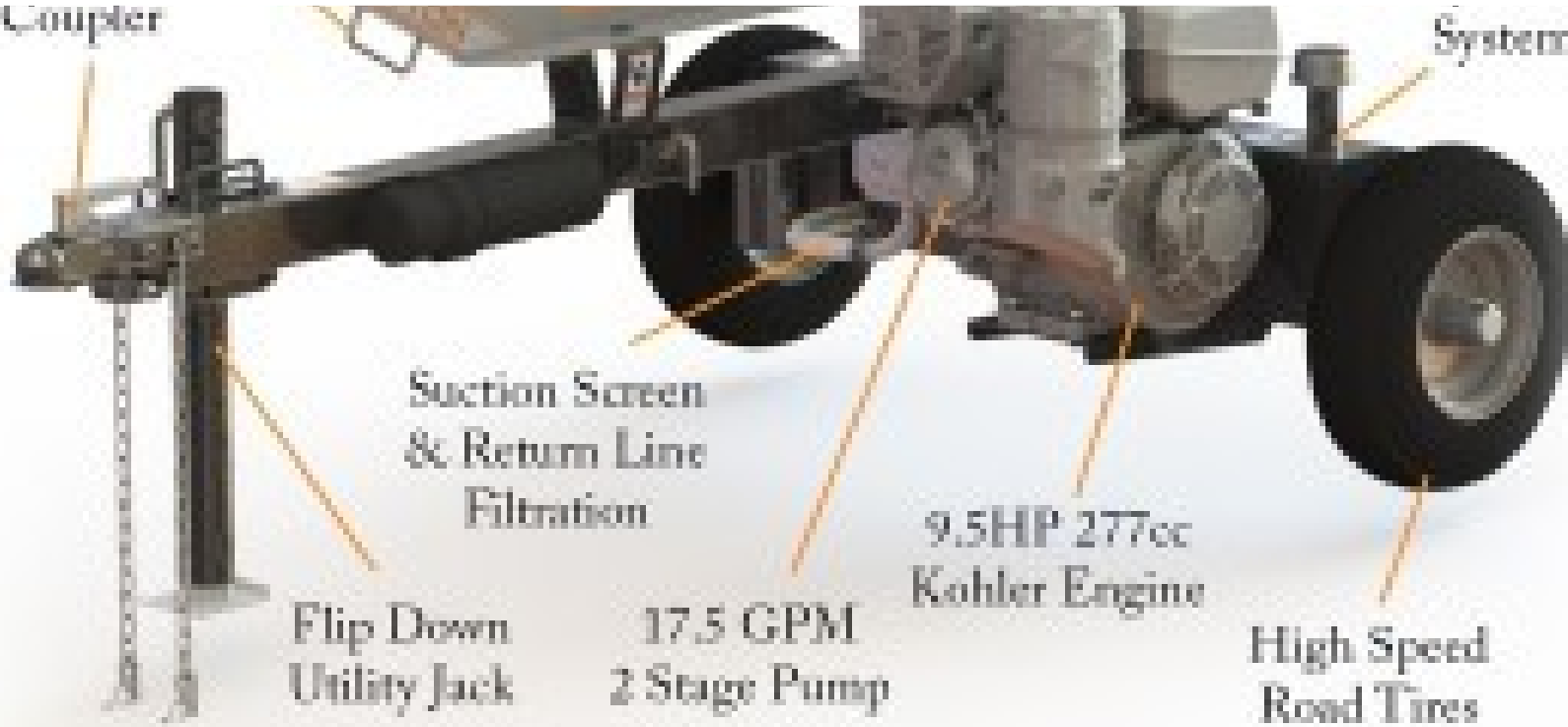

Dirty Hand Tools 35 Ton HV Log Splitter (100466)



~~\$1,649.99~~ \$1,449.99

 Select options

SALE



OUT OF STOCK



Dirty Hand Tools 22 Ton HV Log Splitter (100171)



~~\$1,099.99~~ **\$899.99**

[➔ Select options](#)

SALE





YARDMAX 28 Ton Horizontal Vertical Log Splitter – Half Beam (YS2865)



~~\$1,499.99~~ **\$1,099.99**

 [Select options](#)

HOT

SALE





10 Ton Boss Industrial Dual Action Electric Log Splitter (ED10T20)



~~\$899.99~~ **\$799.99**

 [Select options](#)

SALE



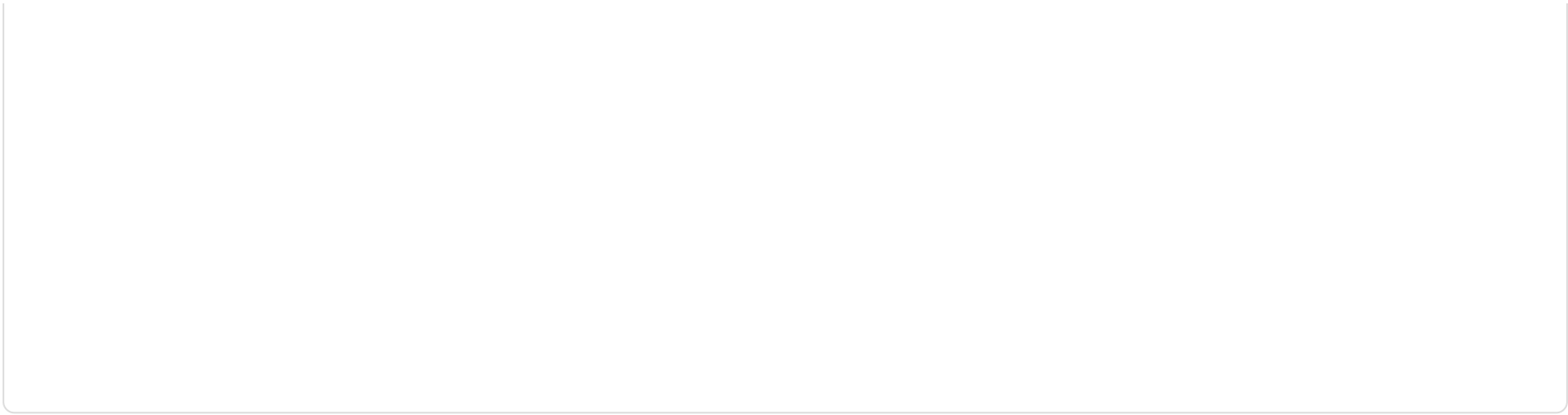

7 Ton Boss Industrial Electric Log Splitter (ES7T20)



~~\$479.99~~ **\$449.99**

 [Select options](#)

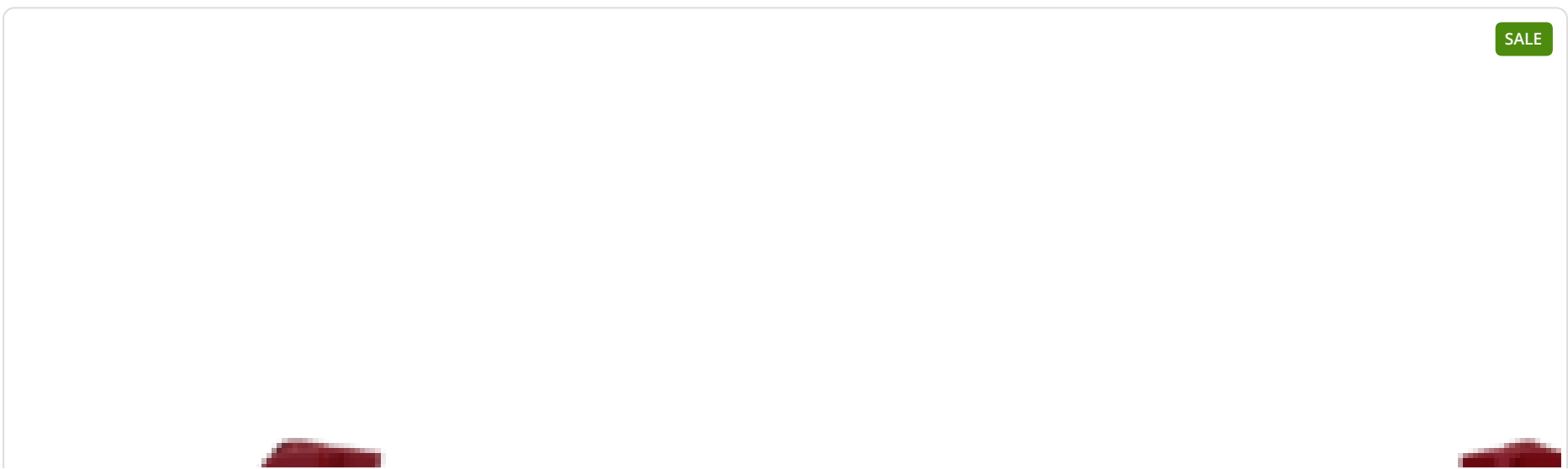

SALE



8 Ton Boss Industrial Dual Action Electric Log Splitter (ED8T20)



~~\$679.99~~ \$599.99

 [Select options](#)

RECENT POSTS

- ▶ [Best Ways to Bundle Firewood](#)
- ▶ [What Is the Best Firewood to Cook With?](#)
- ▶ [Why You Should Have a Dewatering Pump](#)
- ▶ [Things You Might Not Know About the Timber Industry](#)
- ▶ [Best Ways to Keep Your Firewood Dry](#)

GET IN TOUCH

We're always here to help.
Call or email us.



WHICH SPLITTER SHOULD I BUY?

Let us help you make the right decision.



RESOURCE CENTER

Access our knowledge base

CONTACT US

All your questions will be answered

 **888-706-2434**

CUSTOMER SERVICE

- ▶ [Check Order Status](#)
- ▶ [Contact Us](#)

RESOURCES

- ▶ [Guide for Choosing the Right Log Splitter](#)

COMPANY INFO

- ▶ [About Us](#)
- ▶ [Our Blog](#)

OUR COMMERCIAL

Mon - Fri | 9am - 5PM PST

 Email Us



- > Shipping & Delivery
- > Return Policy
- > Financing Options
- > Privacy Policy
- > Terms & Conditions

- > Picking Your Log Splitter Style
 - Gas or Electric?
 - Horizontal or Vertical (or Both)?

> Our Scholarship



GET SPECIAL EMAIL OFFERS

FOLLOW US



100% SECURE PAYMENTS



SECURE ONLINE STORE



woodsplitterdirect.com © All rights reserved