

12-2000

Presentation of the Sun King: The Performance of Power in 17th Century French Ballets des Entrees

David Shuhly

Follow this and additional works at: <http://digitalcommons.library.umaine.edu/etd>

Recommended Citation

Shuhly, David, "Presentation of the Sun King: The Performance of Power in 17th Century French Ballets des Entrees" (2000).
Electronic Theses and Dissertations. 633.
<http://digitalcommons.library.umaine.edu/etd/633>

This Open-Access Thesis is brought to you for free and open access by DigitalCommons@UMaine. It has been accepted for inclusion in Electronic Theses and Dissertations by an authorized administrator of DigitalCommons@UMaine.

**PRESENTATION OF THE SUN KING: THE PERFORMANCE OF POWER
IN 17TH CENTURY FRENCH BALLETS DES ENTREES**

By

David Shuhy

B.A. Salisbury State University, 1996

A THESIS

Submitted in Partial Fulfillment of the

Requirements for the Degree of

Master of Arts

(in Theatre)

The Graduate School

The University of Maine

December, 2000

Advisory Committee:

Thomas Mikotowicz, Associate Professor of Theatre, Advisor

Jane Snider, Associate Professor of Theatre

T. Paul Pfeiffer, Associate Professor of Theatre, Salisbury State University

**PRESENTATION OF THE SUN KING: THE PERFORMANCE OF POWER
IN 17TH CENTURY FRENCH BALLETS DES ENTREES**

By David Shuhy

Thesis Advisor: Dr. Thomas Mikotowicz

An Abstract of the Thesis Presented
in Partial Fulfillment of the Requirements for the
Degree of Master of Arts
(in Theatre)
December, 2000

This study will examine how Cardinal Mazarin, through the ballets *Le Ballet de la Nuit* and *Ballet de la Noces de Pelee et de Thetis*, created the image of Louis XIV as the "Sun King." Mazarin, through the power of theatrics and the performance of power, forged Louis's image from near-exile to absolute monarch.

Both of these ballets created a world, image, and mythology of Louis that affected not only those in attendance, but also the people of France and Europe. Through the use of Italianate scenic practices and technologically advanced machinery, such as Torelli's "chariot-and-pole" system, elaborate costumes, and wonderfully painted and designed settings, a near magical realm was created within the confines of the Petit-Bourbon Hall that amazed those lucky enough to witness it first hand.

The first section of this study will examine the history surrounding these ballets — the political conditions, the economics, and the major events leading up

to the production of these two ballets. The first section will also give a brief overview of the ballets themselves as well as an introduction to the theories used to analyze them. The second section will examine, in depth, each of these ballets as events within their historical context. This section will include major historical events, descriptions of costumes, machinery, and settings, as well as a short socio-political analysis of the ballets. The third section will examine the theories of social psychologist Erving Goffman and performance theorist Richard Schechner and how their theories relate to the production and performance of these two ballets. The conclusion will recap the major premises written about in the first three sections, show how these strategies are still in use, as well as final thoughts on the effects these ballets had on those who witnessed them.

ACKNOWLEDGEMENTS

The author would like to thank Alene Long for her hard work and invaluable help in the translating of certain texts used for this study.

TABLE OF CONTENTS

ACKNOWLEDGEMENTS.....	ii
LIST OF PLATES.....	iv
Chapter	
1. Introduction.....	1
2. Ballets.....	8
2.1 Le Ballet de la Nuit, "The Ballet of the Night," (February 1653).....	8
2.2 Ballet des Noces de Pelee et de Thetis, "The Ballet of the Marriage of Peleus and Thetis," (April 1654).....	18
3. Goffman and Schechner.....	27
4. Conclusion.....	37
WORKS CITED.....	40
APPENDIX A. Illustrations.....	42
APPENDIX B. Original French.....	59
BIOGRAPHY OF THE AUTHOR.....	64

LIST OF PLATES

A.1	Louis XIV as Apollo – <i>Le Ballet de la Nuit</i> – 1653.....	43
A.2	Louis XIV as Apollo – <i>Noces de Pelee et de Thetis</i> – 1654.....	44
A.3	1 st veille – <i>Le Ballet de la Nuit</i> – Entrance of the Night.....	45
A.4	2 nd veille – <i>Le Ballet de la Nuit</i> – 7 th entrée.....	46
A.5	2 nd veille – <i>Le Ballet de la Nuit</i> – The Court of Miracles.....	47
A.6	3 rd veille – <i>Le Ballet de la Nuit</i> – 12 th entrée.....	48
A.7	Act I, scene 3 – <i>Noces de Pelee et de Thetis</i> – Jupiter in the clouds.....	49
A.8	Act II, scene 2 – <i>Noces de Pelee et de Thetis</i> – The Palace of Jupiter.....	50
A.9	Act III, scene 2 – <i>Noces de Pelee et de Thetis</i>	51
A.10	Sebastian Serlio’s Three Scenes.....	52
A.11	Design for Flying Machine.....	53
A.12	Nicolà Sabbatini’s study of a cloud machine.....	54
A.13	Two designs of cloud machines by Nicolà Sabbatini.....	55
A.14	Le Salle de Machine – Previously the Petit-Bourbon Hall.....	56
A.15	“Chariot-and-Pole” system of changing scenery.....	57
A.16	Schechner’s illustration of the relationship between <i>drama, script,</i> <i>theatre, and performance</i>	58

Chapter 1

INTRODUCTION

How does one make the four-year-old son of an ineffectual figurehead one of the most powerful kings in European history? When Louis XIII died, his son (the future Louis XIV) was only four years old and France had been under the control of a series of First Ministers. Cardinal Mazarin, First Minister of France during Louis's minority, was determined to establish the monarchy as the absolute authority of God on earth. He taught Louis that the king was divinely chosen by God to rule over the people of France. More importantly, he also convinced the people of France. When Louis turned thirteen, a massive propaganda campaign began. Mazarin did not stop at the divine placement of the king, but enhanced the concept to include a personification of the celestial. He presented Louis to be the morning sun – a glorious and shining king, rising after the darkness of a turbulent revolution. Louis became a shining king that was, like the sun, the center of all things in his royal universe. This campaign was so successful that Louis's absolutism created a stand for French rule until 1789 – the king was the absolute power in the kingdom. While various tools were used to create this image, the most powerful was the *ballets d'entrees*. Louis was, in a series of ballets, costumed as the sun (shining and bright), personified as Apollo (the god of the sun), lit in golden radiance, and praised in verse written by Isaac Benserade, one

of the best French writers of the time. Through these ballets and the power of theatrics, Louis transformed into that most notable of monarchs – the “Sun King.”

There were many obstacles to overcome before Louis took control of the country. The monarchy, during the reigns of Louis’s parents, had become a powerless, contemptible institution. Louis’s father, Louis XIII, was more interested in his *amour de jour* than the affairs of government. Upon Louis XIII’s death in 1643, Louis’s mother, Anne of Austria, whose upbringing in the Hapsburg court had trained her only as a “trophy” wife, became Regent. “Anne of Austria possessed no qualifications to be Regent of France. She neither wanted nor knew how to govern a kingdom” (Buranelli 17). Both Louis XIII and Anne of Austria, rather than taking up the reins of government themselves, selected First Ministers to oversee the day-to-day responsibilities of government. The first of these ministers was the infamous Cardinal Richelieu, followed by Cardinal Mazarin who, while not as well known, made greater gains in centralizing the power of the French monarchy. Both men took a country that was torn by internal strife and conflict, and formed a powerful, centralized government. Louis XIV was crowned in 1654 while Cardinal Mazarin controlled the country, but did not take independent control of the government until the Cardinal’s death seven years later. During this period of overlap, Mazarin trained Louis in the subtleties of ruling. He taught him when to be lenient and when to punish. “Louis’s education was more practical than formal. Under Mazarin’s instruction, he conscientiously studied state papers as they arrived, and he attended council meetings. He learned

by direct experience...”(McKay 612). Mazarin’s ultimate goal was the complete and total control of the country by its God-ordained ruler – the king.

During the years between the defeat of the revolutionary group the Fronde (comprised of nobles who gained the support of the common people by blaming the problems of the country on Mazarin), in 1653, and the death of Cardinal Mazarin, a number of ballets and other artistic works (including paintings, medallions, and statues), under the Crown’s patronage, presented an image of Louis that catered to the ideals held by the people of France, as well as to the rest of Europe. In these works, Mazarin emphasized Louis’s ability to personally rule the country. Mazarin realized that it was vitally important to show Louis XIV as a figure worthy and capable of running his own government to overcome the stigma that the king existed merely as a figurehead. “The production of various genres of portraiture was so important to the mythology of the Sun King that Louis XIV and his ministers centralized the artistic academies to assure unified and consistent representation”(Murray 108). Through medals, sculptures, poetry, and painting, Mazarin and other ministers force-fed the populace the wonders and marvels of the future king. This activity culminated in a bright and shining hope for France – a Golden Age in which a unified country orbited around Louis as the center of its universe. Thus, through these works, Mazarin had created the “Sun King.”

The most effective of the early works idealizing Louis’s role, however, were the theatrical performances, “a phenomenon that extends far beyond the boundaries of the dramatic poem and the playhouse” (Murray 130). *Le Ballet de*

la Nuit (The Ballet of the Night) and *Ballet des Noces de Pelee et de Thetis* (The Marriage of Pelee and Thetis) were two of many ballets integral to the creation of the image of Louis as the Sun King. The first of these ballets, *Le Ballet de la Nuit*, was presented in February 1653, shortly after the defeat of the Fronde. The story of this ballet followed the activity of a town from dusk until dawn, when, as the rising sun, Louis entered dressed as the “le Soliel levant.” “It was a part from which he gained his famous title, *Le Roi Soliel*, and which he was to play in real life when he assumed the role of absolute monarch”(Clarke 16). This ballet was presented in court within a month of Mazarin’s return from exile – an exile imposed upon the Cardinal by the Fronde (a clear sign that the rebellion was defeated). “The people were crying for peace; moderates were calling for national union under the King...”(Buranelli 25). Both the ballet and the politics focused on the end of rebellion and the coming power of the young king. This ballet is the oldest recorded performance that compares Louis to the sun.

First performed in January 1654, only five months before Louis’s coronation on June 7, 1654, *Ballet des Noces de Pelee et de Thetis*, signaled the permanence and glory of the new reign. “As 1653 ended, the [event] that occupied the attention of everyone was the royal coronation...”(Buranelli 26). A series of ten entrances, written by Isaac Benserade, introduced the fifteen-year-old king, who played six characters including Apollo (Appendix A, Plates 1, 2) and War. Drawings and engravings from the period provide a clear idea of the size and scope of the magnificent entertainment. Among these drawings is a rendering of Louis costumed as Apollo, the god of wisdom and light, portrayed as the sun.

This costume included a massive, feathered headdress with sunbeams emanating from the brow, a doublet and hose covered with miniature suns and rays of light radiating from the neck, sleeves and hem. Louis's descriptive speech about his own magnificence and brilliance (that he was brighter and greater than anything in Heaven or Earth), "Plus brillant & mieux fait que tous les Dieux ensemble,/ La Terre ni le Ciel n'ont rien qui me ressemble" (Silin 236) completes the aggrandized image of the Sun King. Other surviving renderings of the ballet show scenes of gods sitting among the clouds, rising suns casting their brilliance on the stage, and scene upon scene incorporating the latest technological breakthroughs of decoration and design.

These ballets served a greater purpose than blatant flattery and propaganda; they emphasized the need for stability in France in the mid-Seventeenth Century, as well as the government's response to that need. Cardinal Mazarin understood the importance of the idealization of authority as he formed and molded Louis's public image. Social scientist Erving Goffman uses the terms *front* and *idealization* to describe these concepts. According to Goffman every person performs specific roles depending on the given situation and expectations. Applying Goffman's theories to these ballets opens up the motives and "sign equipment" used by Cardinal Mazarin in the creation of Louis's image. Further, performance theorist Richard Schechner's ideas of *drama*, *script*, *theater* and *performance* can be applied to these ballets and can illustrate the cultural significance of Louis's representation through the study of the structure of the event. Schechner, in his theories, carefully divides the different aspects of a

performance into categories. By doing so, analysis of a performance – whatever form it may take – can focus on the layers within the event. Schechner explains, “The drama is the domain of the author, the composer, scenarist; the script is the domain of the teacher, guru, shaman, master; the theater is the domain of the performers; the performance is the domain of the audience” (Schechner Essays 39). Through analyzing the visual and written elements, as well as the roles of the key participants in these ballets, one can develop a better sense of the overall goals of the productions and their effect upon the people of France and Europe.

Even in our own century, these methods have been used and exploited to enhance the public image of those in power, or coming to power. One of the most dramatic examples of this was the rise to absolute power of Adolph Hitler and the Nazi party in Germany during the 1920’s and 1930’s. Before the wars and death camps, this group of people performed a meteoric climb in popularity among the people of Germany, advancing from a fringe group in 1925 to the dominating socio-political group led by an infallible demigod in 1939. Like Cardinal Mazarin, the Nazis used a variety of media including print, radio, and mass spectacle to establish Adolph Hitler as the figure of absolute control in the country:

Any totalitarian system is bound to aim at a maximum identification between the directing leader and the directed masses. To achieve this the leader has to appear at one and the same time as a charismatic superman *and* as a fellow human being. He must be made to seem both distant and near, cunning and simple, lonely under the weight of national decisions,

but approachable and open-minded towards the masses. All his successes are shown in a light that reveals his exceptional infallibility whilst any failure or mistake is explained away as mere hallucination of ignorant onlookers or as a malevolent invention of plotting but frustrated enemies (Bramsted 197).

Of course, to a lesser degree, non-totalitarian entities, as well, employ similar techniques to build the image of their representatives (a political candidate, CEO, or a corporation). These entities incorporate the performing arts, popular entertainments, and mass media into their image creation to lead the spectator to believe that their subjects are desirable, efficient, magnificent, friendly, and helpful.

To accomplish a thorough analysis, this study will be done in four parts. First, this introduction will provide a brief overview of the period, ballets, and tools of interpretation to be used. The next two sections will examine, individually, the two ballets, *La Ballet de la Nuit*, and *Ballet des Noces de Pelee et de Thetis*. These sections will focus on each ballet as an event within its own historical context, and the principles and themes within these ballets. Further, the scenography, consisting of settings, costumes, and theatres, will be described and analyzed to show how it facilitated the underlying message of the production. The final section will further evaluate these ballets using the theories of Schechner and Goffman, and draw pertinent parallels to similar events from our own century.

Chapter 2

BALLETS

2.1 Le Ballet de la Nuit

“The Ballet of the Night”

(February, 1653)

For eight years prior to the performance of *Le Ballet de la Nuit*, Louis’s life was full of chaos and turmoil. Louis was forced to flee from his own capital, his trusted advisor Mazarin was sent into exile, and drawings featuring burlesque caricatures of his mother, the Queen, portrayed as Mazarin’s whore, were handed out in the streets of Paris. Throughout the country, rebellion and war broke out interrupting trade and the day-to-day activities of the people of France – a war that only hurt the country, in which neither side could seem to gain the upper hand, and which made the country vulnerable to foreign invasion. The country became disillusioned by the false promises of the rebellious members of the Fronde, and was sick of a dissident minority disturbing the normal activity of the nation. Throughout the nation, a desire for peace and normalcy grew within the people of all social classes – a desire for a united country lead by the rightful king, rather than a small group of dissidents (Carré, 175).

Louis’s regime took full advantage of the situation. The royalists were able to win several decisive battles – the most important being the recovery of the capital, Paris. Victory was achieved when, at Louis’s call, the general populace of

the city rose to help in the fighting of the usurper Monsieur le Prince (the Fronde's hopeful for the throne). By the winter holiday season, a certain level of calm was restored throughout the more metropolitan areas of the country. "The year 1653, therefore, opened under favourable auspices. The entertainments, of which the Court had been so long deprived, began once more" (Carré 187). For the first time in several years, a certain amount of merriment re-entered the court world, and there was finally hope for a better future.

At the end of January, news of Mazarin's return from exile gave even more reason for the royal family to celebrate. The Cardinal, being able to return from an exile imposed by his and Louis's political enemies, heralded for many the return to life as it had been, and an end to the rebellious Fronde. "... all the court came to pay their respects to the Cardinal-Minister, who received their compliments with smiling affability, 'and those who had shouted loudest against him were not the last to do him honour'," (Carré 188). Mazarin's return was surrounded by festivity. Carré states that in honor of the Cardinal's return, banquets were to be held – paid for by the newly reopened Municipal Finance Office. Louis's regime not only had overcome the near bankruptcy that continuous fighting and an irregular economy had created, but also used these monies to support the festivities, banquets, dances, fireworks, and ballets that filled the Twelfth Night and Carnival (what are now the Christmas and Mardi Gras seasons). It was as part of these festivities, and this rejuvenated political scene, that *Le Ballet de la Nuit* was performed.

The ballet was first performed in the Petit-Bourbon Hall on February twenty-third, and consisted of a series of forty-three *entrees*, in four sections – each section representing a watch of the night spanning from dusk to dawn. The ballet began with the personified characters of the Sun setting far away over the sea, and the Night entering on a chariot of clouds being pulled by owls (Appendix A, Plate 3). The ability to portray a setting sun on-stage in a world lit mainly by candlelight and oil lamp must have seemed almost magical to the audience. In this opening scene, above center stage, glowing and surrounded by clouds, were the royal arms of the French crown, in the place normally reserved for gods and other great powers. This ballet, produced shortly after Mazarin’s return from exile, clearly implied to the audience the absolute power of King Louis as God’s representative on earth. Following this, each section of the ballet revealed a piece of life in Paris from the “Court of Miracles” (Appendix A, Plate 5) where beggars come to be healed of their afflictions, to a fashionable boutique where ladies and gentlemen are buying ribbons and jams (Appendix A, Plate 4). Scene follows scene of a life denied to many due to unrest, barricades, sieges, and open fighting in the streets. The ballet reached its climax with the entrance of the young monarch Louis dressed as the rising Sun. Sleep and Silence, “awaken by the reputation of the sovereign king, sing: Of this young Louis the dawn marvels”¹ (Christout Le Ballet de Cour de Louis XIV 70), and introduce Louis as the greatest king in the world, one that even Silence could not stop praising:

¹ Appendix B, Passage 1

In the “Recit de l’Aurora,” inspired by the thought that his idol here represents “le Soliel Levant!” – an appearance of a conception that will persist as long as Louis XIV dances in ballets – Benserade attains new heights of eloquence... (Silin 221).

At the approach of Louis – the rising sun, the new morning – the creatures and entities of the night flee “when they see the [S]un rise[,] incarnated by Louis XIV. The King is presented for the first time under this [image] that will become his most precious emblem. He dances the great final ballet accompanied by the genies of Honor, of Grace, of Love, of Value, of Victory, of Favor, of Renown, of Peace... who come to present their respect”² (Christout Le Ballet de Cour de Louis XIV 71). It is this, Louis’s first appearance as Apollo in *Le Ballet de la Nuit*, that gave him the title of the Sun King. One can see in the plate (Appendix A, Plate 1) the careful detail of sunbursts, gold work, and gems that comprised the costume, and the massive headdress that greatly increased the fourteen-year-old king’s stature. Louis’s stance, with one leg slightly forward and toe pointed, emphasizes the attractive shape of the young man’s leg – one of the greatest ideals of beauty in a court famous for dancing. The entire image of Louis as the Sun King and Apollo was carefully designed to create an image of beauty, glory, and radiance in the minds of the spectators.

This ballet draws obvious parallels between the state of the country and the actions on the stage. France, having come out of a “dark night” of its own, is

² Appendix B, Passage 2

now entering a new dawn under the shining guidance and influence of Louis. To be sure that this message was fully understood and disseminated (among the courtiers and people of Paris), the ballet was given five times, “ ‘so that all in the city could attend this excellent entertainment and satisfy their longing to gaze at the King.’ The doors of the Petit-Bourbon hall were thrown open to the public for this purpose” (Carré 189).

This ballet was not only for entertainment purposes, however, but a display for the audience of Louis’s kindness, magnanimity, grandeur, and glory. The audience, upon several levels, and through a variety of media, was publicly introduced to those qualities of the king that would allow him to rule and carry France to new heights. Louis, being portrayed as the sun, and accompanied by the virtues of love, grace, valor, favor, renown, and peace, was clearly identified as one who was set above those “common” people and worthy of the crown – as shown by his recent exploits in the field. Even before the show began, Louis had opportunity to show off his mettle as a leader:

[The ballet] just missed being by a slight outbreak of fire when a curtain burst into flames. “The mishap only served to make people admire the coolness and courage of His Majesty, who, to prevent the panic which would have occurred had he betrayed any fear, remained perfectly calm and so reassured the audience as formerly Caesar had reassured the pilot who, pale with terror, was steering him through a tempest which threatened him with shipwreck...” (Carré 188).

Beyond the written script of the ballet, the Petit-Bourbon and the physical staging of the ballet (including the machines, costumes, and settings) may have had an even greater impact upon the audience. While there is no existing plan for the Petit-Bourbon, its successor, *Le Salle de Machines* (Appendix A, Plate 14), the largest theatre of the period in Europe gives one an idea of the scale and scope of these halls. Typical of the private indoor theatres common in France and Italy during this period, the stage space takes up more room than the auditorium. These theatres, designed for elaborate scene changes, were marvels of technology, and were showpieces for an elegant court. Unlike the public theatres of England, these theatres made great use of spectacle and the shifting of scenery quickly and efficiently as part of the action of the play. The Petit-Bourbon, recently renovated by Mazarin's order in 1645 by Giacomo Torelli – one of the most renowned Italian designers of the time, and also the designer for both this ballet and *Le Ballet des Noces de Pelee et de Thetis* – was the epitome of technology in theatrical design for the period. The first truly Italianate theatre in France, it was fitted with the chariot-and-pole system (Appendix A, Plate 15) which allowed scene changes to occur right before the eyes of the audience. This system implemented a series of wheeled chariots beneath the stage attached to ropes and pulleys that allowed the shifting of scenery by turning the central cylinder. The existence of such machinery on the stage gives one an idea of the importance of spectacle in the French court. Just as statuary, gardens, medallions, and fine clothing showed the greatness, wealth, and power of the monarch – so too the

theatre and performance of the court reflected directly upon the crown. This renovated theatre created a vogue for “machine plays” in France, visual spectacles designed to showcase theatrical technology, which had not declined by the time of *Le Ballet de la Nuit*. The near magical ability of this theatre to change from a scene at the seashore, to an alleyway in the city, and to a distant cave was wondrous to a seventeenth-century audience. This ballet contained chariots drawn by owls, deities floating in clouds above the stage, rolling waves, and even lighting changes; indeed, one scene portrayed people running to fight a roaring blaze consuming a building in the middle of the night (Appendix A, Plate 6). This fire could have been portrayed in several ways, either as part of the painted scenery, an effect created by lanterns and reflected light, or through dousing a cloth in a flammable liquid and then suspending it behind the scenic piece.

A personal spectator, Loret, a critic, who, by his own admission, had “the worst seat in the house”³ gave his account of opening night.⁴ Although, due to his bad seat, this account was probably “drawn largely from the printed program” (Silin 214) being mostly a description of the locales and settings of the scenes and dancers, Loret praises the unparalleled and miraculous machines that allowed the metamorphoses between scenes and locale. Having obtained a better seat for a performance on March Sixth, Loret gave a bit more detail of the show. “So many grand and beautiful things within the royal and brilliant place!”⁵ The official account by Renaudt in *La Gazette*, a government subsidized paper, states:

³ Appendix B, Passage 3

⁴ Appendix B, Passage 4

⁵ Appendix B, PPassage 5

“These forty-three *entrees* of the Royal Ballet, Night,” wrote *La Gazette*, “were all so rich in novelty of production, in elegance of verse, in mechanical ingenuity, in magnificence of costume and in dexterity of performance that the spectators would have found it difficult to say which were the most beautiful of them...”⁶ (Carré 189).

Even those who were not affiliated with the official state controlled *La Gazette* reported their admiration of the wonders of the ballet. “To the enthusiastic accounts of the official gazetteers may be added the appreciation of a *connaissanceur*, le père Ménestrier” (Silin 216). Ménestrier reports “M. Clement, who was incomparable in all his ingenious work, surpassed himself and we had to have as well as himself all the sciences of the feasts and representations to imagine such beautiful things”⁷ (Silin 216).

Indeed, besides the architecture and machinery of the Petit-Bourbon, the costumes of de Gissey were just as amazing to the onlooker. Funded by a newly economically recovered state, the costumes were both sumptuous and flamboyant. Christout explains in her book that the ballet, existing independently of the “real world,” was free to indulge itself in the fantasies of the designer. It was, however, irrevocably tied to the need to present the characters dancing before the audience clearly and immediately (Christout *Le Ballet de Cour de Louis XIV* 167).⁸

⁶ Appendix B, Passage 6

⁷ Appendix B, Passage 7

⁸ Appendix B, Passage 8

The costumes themselves were extravagant in their richness being made of silk, velvet, gauze, muslin, gold, silver, satin, and covered with embroideries and precious gems.⁹ “Even more than the movements, which often remained only slightly differentiated, costumes, machines and accessories allowed the identification of divinity... The symbolism was so familiar to everyone that each detail ensured immediate identification... The very young Louis XIV brilliantly incarnated Apollo and was soon remembered everywhere as the *Roi-Soleil*” (Christout Le Ballet de Cour au XVII^e Siècle 22-3). For this specific ballet Louis was dressed as the sun complete with headdress and rays emanating from the sleeves and waist of his doublet. The headdress, framing Louis’s face in flaming rays as well, not only crowned him regally, but also added a great deal of height to his stature – a beneficial aspect for a young man of fourteen. The materials and allegorical references of Louis’s costume brought to mind images of not only great wealth and power, but, strengthened by the praises of Silence and Sleep, a new beginning for France after years of warfare and decline. The “*levant Soliel*” which the audience saw before them was not only a character in a ballet, but also the embodiment of the changes that would come, now that Louis had come back to Paris and the Fronde was on the run.

Thus, the production presented Louis as the rising sun to the audience of both France and Europe, for this ballet had implications beyond the borders of the country. Diplomats from surrounding countries who represented their country

⁹ Appendix B, Passage 9

and kings, as well as the nobility of France, whether they were loyal or dissident, had their first view of Louis XIV. Although Louis was still overshadowed in his governing role by his First Minister Cardinal Mazarin, the ballet exhibited those qualities of Louis's that caused him to be a force to be reckoned with. As well, there existed the metaphorical implication that Mazarin would eventually step aside for the dawning of Louis XIV as he emerged as a monarch and power in his own country, and the rest of Europe. No longer was Louis the child being dragged by his mother and minister from refuge to refuge, but he now became Louis XIV from whom his adversaries, like the powers of night, would retreat.

2.2 Ballet des Noces de Pelee et de Thetis

“The Ballet of the Marriage of Peleus and Thetis”

(April, 1654)

The year of 1653 was a time of overcoming the final remnants of the Fronde and finalizing Louis’s control of France. The last strongholds of rebellion in the country, mostly in the outlying provinces, were overcome. Louis, at the head of his own army, stayed out upon the campaign through November, laying siege to towns which failed to capitulate to his authority. On January 19th, Louis took the final step to total mastery of his country. He went before Parlement and demanded that the head of the rival faction, Monsieur le Prince, appear before him within the month to answer the charges of high treason. Failing to do so, M. le Prince, “forfeited all his functions, offices and titles, depriving him of the name of Bourbon and the rank of Prince of the Blood and condemning him ‘to suffer the penalty of death in such manner as the King shall be pleased to ordain’,” (Carré 204). With the Fronde effectively shattered, the king could look to other matters of state, including his coronation. While Louis technically became king upon his father’s death in 1641, and had reached his majority at the age of thirteen on September 10, 1651, he was not crowned until June 7th 1654. At the age of fifteen, Louis became the king of the newly reunified France, and under his direction (and Mazarin’s) the country became the model of absolute monarchy, and arguably the most powerful nation in Europe.

Surrounded by this flurry of activity, *Ballet des Noces de Pelee et de Thetis* was being prepared and performed. “The beginning of the preparations for

the *Ballet des Noces de Pelée et de Thétis* may be placed as early as January 26, 1654, when the Italian actors and musicians arrived in Paris...” (Silin 232). The first performance was given on April 11th at the Petit-Bourbon and the final on May 23rd – only a few weeks before the King’s coronation. This ballet, like *Nuit* was danced several times so that both native and foreigner could witness the magnificence themselves. “...Loret notes that the king is dancing the ballet three times a week in order that everyone may see this rare spectacle which is winning the admiration of many a foreign agent and ambassador” (Silin 233). Among these foreign spectators was another monarch (Charles II of England) who was living in exile as the result of civil war, like Louis himself had been so recently, and this ballet proved to be a wonderful opportunity for Cardinal Mazarin to showcase the magnificence of the king of France.

“The foreign ambassadors that were invited including[,] King Charles II of England and his mother Henriette of France, admired the delicate music, the beauty of the parts of the ballet, the variety and riches of the décor and machines...”¹⁰ (Christout Le Ballet de Cour de Louis XIV 72). Not only was Louis opening his borders to a fellow king, but the display of wealth and grace which the situation allowed gave a clear impression that the time of struggle for France was at an end and that Louis was indeed master in his own country. The abundance of wealth and opulence allowed Mazarin to showcase for the future Charles II, and all of Europe, that Louis was in control, and that the power in the country was solely in the hands of those loyal to the cause and well-being of the

¹⁰ Appendix B, Passage 10

Crown. “Perhaps the most important piece of sign-equipment associated with social class consists of the status symbols through which material wealth is expressed” (Goffman 36). Once again, as in *Le Ballet de la Nuit*, Louis is dressed as the rising sun (Appendix A, Plate 2). This was Louis XIV’s second appearance as the god Apollo. With his coronation only a few weeks after the closing of the production, Louis, in this ballet, was already crowned in the light of the sun. The costume, a variation of common dress of the period, was covered with iconographical images relating Louis/Apollo to the Sun. This costume, with the emphasis on his golden curls and beatific smile emphasizes Louis’s grace and the attractiveness of his youth – rather than letting Louis’s age become a hindrance, it is incorporated into the design. According to Loret, a writer for *La Gazette*, the event was full of amazing and wonderful things that would have left Louis’s spectators, both royal and common, with the impression that they witnessed greatness. “Never has more stately theatre been witnessed by the human eye, never have delightful aspects so enchanted the eyes, and never had Protee, whose fable is sung everywhere, shown in a few moments such marvelous transformations...”¹¹ (Silin 233).

Nearly a hundred years previous to these ballets, Sebastiano Serlio, an Italian architect deciphered Roman writings on theatre in his books on architecture and devised three scenes that he believed should be used for any setting (Appendix A, Plate 10). First was the “comic” which portrays everyday households, next was the “tragic” setting depicting temples and noble

¹¹ Appendix B, Passage 11

households, finally there was the “pastoral” which portrays a natural setting. Elements of these designs can be seen even later in Torelli’s designs. It is mainly from these three designs that the “new stagecraft” in the Renaissance came to be. Notable within these drawings are the carefully drawn perspective, the idea of balance, and cleanness and clearness of the images. Torelli, using these three motifs presented by Serlio expanded them to incorporate caves, seashores, and palaces – but all from these similar ideals.

In the *Ballet de la Noces de Pelee et de Thetis*, one can easily see both Serlio’s influence and the grand scale of the design. In Act I, scene iii (Appendix A, Plate 7) one sees Jupiter swooping down from the clouds to carry off Thetis. This shows the versatility and mobility of the flying machines that could move not only up and down, but also from side to side, and in some cases up and down stage. As part of Jupiter’s costume, rays of light emanated from his head – this affect may have been achieved with the use of a headdress, but more likely was a lighting effect using gold leaf and lantern light to create the shimmering, radiance befitting a deity. This scene has distinct characteristics based upon Serlio’s pastoral scene, located in a wild place with the cavernous rock walls surrounding the action. Also of note is the great variation between this design and Act II, Scene ii (Appendix A, Plate 8) – the versatility of these theatres to change locale before the audience’s eyes created the vogue for “machine plays.” In Act II, Scene ii the opulence of Giacomo Torelli’s design can be seen in his use of Corinthian columns that were further ornamented with multi color stones on a background of lapis lazuli (Christout, 24). The image created in this scene is

obviously meant to overwhelm and delight the spectator with magnificence – from Mercury crossing above the stage to the elegant dancers in the foreground. In Act III, scene ii (Appendix A, Plate 9) one gains an idea of the grand scale of these productions. The bank of clouds, most likely a cloud machine and Glory Box (which were rings of clouds, or some other heavenly body, which framed the scene), was large enough for several dancers. These machines, marvels of ingenuity by any standards, must have been an awesome sight for any spectator.

The ballet itself consisted of ten *entrees* inserted into a full-length opera. What otherwise would have possibly been a minor courtly diversion, was, due to its integration into a full-scale opera, produced on an amazingly grand scale.

In discussing this ballet one must not forget that it was intended as a minor embellishment for a much more important and imposing, if less successful, entertainment: *Le Nozze di Peleo e Theti*, Mazarin's third attempt to acclimate the Italian opera in France... it was inconceivable that the king would sit through several hours of a musical performance without indulging his predilection for dancing. It was therefore decided to intercalate between the acts of the Italian opera a French ballet which would afford the king and his courtiers an opportunity to display their dancing talents and their magnificent costumes (Silin 233-4).

The ballet and opera were performed in the Petit-Bourbon with all the settings and machinery afforded to Mazarin's pet project, including the incredible talents of

Giacomo Torelli. Torelli had designed the successful settings for *Le Ballet de la Nuit* as well. According to Christout, with this ballet Torelli surpassed himself and finally became the undisputed master designer of the ballets. “Finally, the performance owes a part of its singular brilliance to the décor makers and costume designers, meaning Torelli and de Gissey whom, faithful to Mazarin, surpasses himself and finally affirms his position which had for a long time been threatened...”¹² (Christout Le Ballet de Cour de Louis XIV 73).

The ballet begins with a definite sign of the political situation of France. “As the curtain lifts, we discover first a wooded scene surrounding a high mountain shaped as an *arc de triomphe* on which Apollo is throned, played by the King...”¹³ (Christout Le Ballet de Cour de Louis XIV 73). From the beginning of the ballet the spectator is introduced to Louis as throned in triumph as the god of light, complete with golden rays emanating from head, waist, and hand. This portrayal also gives the spectator the vision of Louis as Apollo’s other titles, such as the god of prophecy, poetry, and intellectual pursuit – all characteristics fitting a monarch. “More shining and greater than all the Gods together,/ The Earth nor the Sky do not have anything which compares to me;/ Immortal rays crown my face;/ In love with only the beauty of Victory/ I run unceasingly after Glory ...”¹⁴ (Silin 236). Louis’s grandeur and majesty are unparalleled within a kingdom that is no longer divided by trouble and strife. As prophet, Louis/Apollo proclaimed a

¹² Appendix B, Passage 12

¹³ Appendix B, Passage 13

¹⁴ Appendix B, Passage 14

reign that could not be equaled by even the assembled gods. He is devoted to Glory and Victory, and will chase after both of these things unceasingly.

And if the prince himself appeared as the sun in a ballet, or as Apollo, enthroned in clouds, in the final tableau, the onlooker must have been overwhelmed by his power and majesty. He did not merely act the part of the sun or the god; he was himself an absolute, the ruler by God's grace. (Baur-Heinhold 8)

As in *Le Ballet de la Nuit* this opera/ballet was performed in the Petit-Bourbon, and was a miraculous spectacle of technology and opulence. The hall itself, as has been mentioned in the previous section, contained the latest in scene changing technology –renovated by Torelli in the previous decade. And, as was the situation with *Le Ballet de la Nuit*, the vogue for the “machine play” – an entertainment based on the mechanical wonders of newly designed methods of “metamorphosing” from one scene to the next before the eyes of the audience – continued. The *Ballet des Noces de Pelee et de Thetis* contained all of those wondrous machines that amazed and amused spectators. The most used were the “cloud machines” (Appendix A, Plates 11, 12, 13) and “glory boxes” in the sky that allowed gods to appear floating in the air sitting on thrones in the clouds high above the stage. Devices such as these were used to present deities high above the stage. Some of these machines were large enough to seat thirty people. In the drawing can be seen not only the finished product, but also the mechanics behind

the device. These devices were not limited to vertical movement, but could also move side to side – and in some instances up-down stage. Even lighting had its place in the seventeenth-century production. These cloud machines and glory boxes were lit using candles, lamps, reflectors, gold foil, and other methods to present the god in brilliant splendor. Performed indoors, the scene had to be lit artificially, and several methods of controlling and coloring the lighting were in common use among the “master machinists” of the time.

Clouds gleamed as if made of gold, or were pierced by lights carried within them. Lights were shone on stars in such a way that they reflected the ray and appeared to emanate from the god they surrounded. Clouds reddened and glowed in bengal fire, the flames of hell danced orange and crimson. Parigi and Torelli were the new magicians, conjurors with cloud machines, light and shadow. Colour and light played on each other increasing the illusion and the enchantment, and mirrors reflected and multiplied the brilliance. There was nothing static on the stage; variation and movement were the only constants. Bright lights also enhanced the actors’ glittering costumes; the audience gasped as gold and silver ornaments, shining silks and coloured stones flashed and gleamed (Baur-Heinhold 122).

The sight of the magnificent king glowing and bedecked in golden rays, ruling over the scene from high above must have been inspiring for even the most jaded spectator whose life was lit only by sun and oil lamp. More important than words recited by a courtier, Louis, in these ballets, looked the role of the Sun King.

On several levels this ballet communicated to those in attendance that Louis, as King, was to rule over everything. He was the Sun King. The repercussions of this ballet traveled beyond the borders of France as well. To Charles II, who sat in attendance, the ballet showed a ruler who overcame the struggle in which Charles' father had failed – and now Charles II sat in exile in foreign lands. To those people of Spain and the Netherlands, the enemies of France who had helped the now defeated M. le Prince in his rebellion, whether through first hand account from an ambassador, or through word of mouth, *Ballet des Noces de Pelee et de Thetis* was both a challenge and proclamation. The ballet proclaimed that Louis was master in his own country, and dared any future hopeful usurpers to try their luck against the undisputed ruler of France. These images must have been still fresh in the minds of nobles, ambassadors, and the common people when, less than two weeks after the final performance, Louis progressed to the cathedral at Rheims to be crowned King of France. On his journey, “The inhabitants and the villagers from the surrounding countryside crowded the streets along which he passed, ‘to feast their eyes on the Sovereign on whom they could not gaze enough and to express their joy by overwhelming him with cheers and blessings’” (Carré 206).

Chapter 3

GOFFMAN AND SCHECHNER

Both of the ballets, *Le Ballet de la Nuit* and *Ballet des Noces de Pelee et de Thetis*, were events that filled the imaginations of the spectators with images of grandeur, magnanimity, and wonder. These events, although created to entertain royal persons, served to inculcate the ideas and ideals of the king into the hearts and minds of the viewers. "By the use of these spectacles, sovereigns sought spontaneously to dissuade their subjects from undertaking seditious actions" (Christout Le Ballet de Cour au XVII^e Siècle 8). The tactics and strategies of disseminating the message of Louis XIV as the supreme power in France, and the earth, as ordained by God himself, and their use in these ballets can be isolated and remarked upon, each in turn. "Its secret aim was to educate and inform (while amusing) to strike the imagination and to thus impress, [sic] essential ideas" (Ibid 7). Social psychologist Erving Goffman's theories of the presentation of self and the roles that people enact in public situations, and performance theorist Richard Schechner's theories dealing with the levels of performance can be applied to the ballets to aid in the understanding of the effect that such events would have on the spectators.

Social psychologist, Erving Goffman's theories are useful for focusing on the manner in which the roles were portrayed within the ballets, and the rest of

Louis's life, rather than focusing on the ballet as an event. Goffman's writings on the *front*, comprised of *setting*, *appearance*, and *manner* can help one to understand the careful interplay created during these ballets.

It will be convenient to label as "front" that part of the individual's performance which regularly functions in a general and fixed fashion to define the situation for those who observe the performance. Front, then, is the expressive equipment of a standard kind intentionally or unwittingly employed by the individual during his performance... First, there is the "setting" involving furniture, décor, physical layout, and other background items which supply the scenery and stage props for the spate of human action played out before, within, or upon it... "Appearance" may be taken to refer to those stimuli which function at the time to tell us of the performer's social statuses... "Manner" may be taken to refer to those stimuli which function at the time to warn us of the interaction role the performer will expect to play in the oncoming situation (Goffman 22 – 4).

The *front*, then, is "the expressive equipment of a standard kind intentionally or unwittingly employed by the individual during his performance"(Goffman 22). The *front* is the characteristics and traits one portrays and enacts when presenting themselves in different situations – whether is it intentional or not. Goffman further illuminates this presentation of self in his writings on *idealization*. "When the individual presents himself before others, his performance will tend to

incorporate and exemplify the officially accredited values of the society ... as an expressive rejuvenation and reaffirmation of the moral values of the community” (Ibid 35-6). The performance event, as controlled and contrived as it may be, is the reality of the order of society, and reinforces those things which society believes to be true. These ballets showed that, just as the sun is the center of the solar system, Louis, as the Sun King, was the center of France.

Using the ideas described by Goffman, Louis’s role in the ballet becomes greater than that of a performer in a ballet, even if he is considered the central figure in the story being performed. It was the presentation of Louis as the King of France, dancing as the god Apollo within the physical context of the Petit-Bourbon that separated him from the commoner or noble watching from the audience. Louis performed a multitude of roles simultaneously, some obvious to the onlooker and others hidden to all but the initiated, which gave the combined impression of being the presence of greatness. The *setting*, *appearance*, and *manner* of these ballets are closely interwoven aspects of the greater concept of *front*. The *setting*, being the purely physical aspects, such as the cloud machines, the Petit-Bourbon Hall, and expensive costumes, was also important for the *appearance* and *manner*. The *appearance*, however, is how these elements affected Louis’s social status. These physical attributes displayed Louis’s wealth and power by their mere cost. As to *manner*, the spectators knew that Louis, while portraying a character, was also portraying those qualities he had in common with the character. It is the allegorical reference which distinguishes the

ballets' *manner*. All these aspects give one an idea of the *front* presented of Louis before the assembled audience.

Even though the general perception of Louis during these ballets may have, to some onlookers, been obvious contrivance, the spectators accepted those ideas put forth as true and honest.

[The] inhibitions of the audience allow the performer some elbow room in building up an impression of his own choice and allow him to function, for his own good or the audience's, as a protection or a threat that close inspection would destroy... the matters which the audience leave alone because of their awe of the performer are likely to be the matters about which he would feel shame were a disclosure to occur (Goffman 69 – 70).

This mutual understanding between audience and performer in situations in which the performer is held in respect or awe allowed Mazarin to present Louis in such a way that aggrandized the public perception of the king and his role in the politics of the time. These ballets allowed Mazarin to plan blatant mystification of Louis XIV as the Sun King in a style that would be easily accepted by those who would otherwise question the motivation and appropriateness of the portrayal. In effect, in accordance with Goffman's theory, it was the public's mystification of Louis's role as king that allowed Mazarin to further manipulate Louis's image into that of the Sun King.

Performance theorist Richard Schechner carefully delineates between the levels of the performance event, through describing the specific purposes, happenings, participants, and results. Schechner uses the terms *drama*, *script*, *theatre*, and *performance* to label each of these distinctions within the event. He views these levels as a series of concentric circles (Appendix A, Plate 16), the innermost is *drama* and the outermost is *performance*; each of these circles contains all those aspects which exist “within” their field. *Drama*, Schechner’s most basic unit of the performance event, is that part which can exist without performer or performance. The *drama* is “a written narrative text, score, scenario, instruction, plan or map” (Schechner Essays 39). The *drama* of these ballets was the territory of such people as Isaac Benserade, the poet who wrote these two ballets, Giacomo Torelli, the scenarist who devised the settings, and Henry de Gissey who designed the majority of the costumes. Schechner’s next layer is the *script*, which contains the grander ideas and themes of the event, “all that can be transmitted from time to time and place to place; the basic code of the event. The script is transmitted person to person and the transmitter is not a mere messenger; the transmitter of the script must know the script and be able to teach it to others” (Ibid). In France it was Mazarin who created the *script* of these *ballet de cour*, he was the one who formed and molded the message of the event, and it was he who taught that message to Louis and the spectators. The next layer of the event is *theatre*, “the event enacted by a specific group of performers; what actually occurs to the performers during a production. The theatre is concrete and immediate. Usually the theatre is the response of the performers to the drama

and/or the script...” (Ibid). This is the layer of the event in which Louis takes part. Louis XIV performed the script created by Mazarin, both on and off-stage. This layer is where the themes and ideas are put into action that is observable. Finally, *performance* is the largest and most inclusive of Schechner’s levels. *Performance* is “The whole constellation of events, most of them passing unnoticed, that takes place in both performers and audience from the time the first spectator enters the field of the performance – the precinct where the theatre takes place – to the time the last spectator leaves” (Ibid). This layer of the event, in some aspects, is the most important to this study, this is the level in which the spectators – whether they are witnessing the event firsthand, or are learning of it through engravings, written description, or word of mouth – evaluated and interpreted the ballet. This is the level in which Mazarin’s success can be measured.

In application, Schechner’s theories give a more complete picture of the ballet as an event in history, and allow the study of the layers of the ballet. The *dramas* of these ballets were devised mainly by Torelli, Benserade, and de Gissey. These men created the aspects of the ballets that could be taken from one place to another independent of actors or larger meaning – indeed, the poetry, renderings, and sketches still exist. The grandiose scale and flattering language of these ballets are evident at this level, and remind one, in such phrases as “*Plus brillant & mieux fait que tous les Dieux ensemble, La Terre ni le Ciel n’ont rien qui me ressemble*” (Silin 236) (“Brighter and greater than the assembled Gods, neither the Earth nor the Heavens contain anything that resembles me”) that these

events fulfilled the desire of the people for something greater than themselves. “This new genre thus responded to a triple aim: to inform the curious, to guide subjects by glorifying the prince – God’s image on earth – to enchant by entertaining a hierarchical but turbulent society by momentarily releasing its aggressiveness and its violence, without forgetting to satisfy an eroticism shared between wanton freshness and gallant preciousity” (Christout Le Ballet de Cour au XVII^e Siècle 8). It is the *drama* that contains the magnificent scenery, machines, theatre architecture, spectacle, costumes, and poetry of the ballets.

The ballets’ *script* moved the event beyond the level of momentary entertainment for the powerful, and allowed them to become events with greater implications. It was the message behind these courtly entertainments that created and maintained the idyllic image of Louis those early years after the Fronde. While Louis XIV was still, in actuality, a near powerless, near penniless pupil of the Cardinal, Mazarin developed for the youth a personal mythology to be presented in some of the most sumptuous banqueting halls in the country. Mazarin, through these ballets, created a picture of Louis that persists to the present day. Mazarin was able to transform Louis XIV, who was only a pubescent teenager, into “le Soliel levant,” the rising Sun. Like his predecessor, the infamous Cardinal Richelieu, Mazarin focused on the arts as a method of impressing upon the people, of France and Europe, the greatness and supreme position of the crown. “Script is the domain of the teacher, guru, shaman, master” (Schechner Essays 39). In the mid-1600’s in France, Mazarin became a combination of all of these – the teacher instructing both king and country, the

guru holding the knowledge, the shaman working miracles of spectacle, and the master in control of all the diverse elements of both country and ballet.

The components of *theatre* and *performance* were closely interlaced in these ballets. Louis, the primary figure of the *theatre* in these ballets was also the central focus of the *performance*. It was Louis's personal performance in the *theatre* event that allowed these ballets to have such a strong impact upon the audience. Louis was not a spectator being paralleled to a specific mythological figure through allegorical representation, but rather was the deity himself, performing his own mythology on stage in view of all who could see. This was the greatest difference between the ballets of Louis's court, and the masques of England earlier in the century – unlike Charles I of England, Louis was the central performer in these ballets, thinly veiled by a mask of metaphor, not merely a bystander watching others perform. The *performance* of this event had implications that went much further than the “precinct of the theatre” as Schechner puts it – or rather, the theatre's precinct extended to the furthest reaches of Europe. Witnessing these ballets were ambassadors and noble guests from all of France and Europe, developing opinions of not only Louis's character, but abilities, wealth, position, control, and power. It was here, during these ballets, so soon after civil war and so soon before his coronation, that they shaped their initial opinions of Louis the man and king – and through these ballets that the common people of France were first exposed to their king in all his glory. The doors of the Petit-Bourbon were opened to the public for these performances to allow an even larger crowd to witness the event, also each of these ballets were

given several times to increase the size of the immediate audience. Even if one could not attend the ballets in person, in-depth descriptions of these thirteen-hour events were disseminated by *La Gazette*, the official paper of the government.

Through application of the terms and theories of Goffman and Schechner to these two ballets it becomes plain that these ballets, beyond form of entertainment, played central roles in the mystification of Louis. Mazarin used the ideas of the *front* to display before the people of France and Europe a vision of Louis that was not the scared child, or the awkward teenager, but rather that of the all powerful, near deified Sun King. In these ballets there is no doubt as to who is in control and who holds the power, and in these ballets, there is no Fronde or detracting voices; but rather there is only the opulence, grandeur and magnanimity of the King of France. These were not mere diversions, but rather strategies for disseminating the ideals of the crown, and the creation of Louis's personal mythology. The *drama, script, theatre, and performance* of these events shows them as socio-cultural events in a historical context. One can observe the interplay of the layers of the ballets and how careful planning allowed manipulation of the individual aspects to first create and then to strengthen the ideals of the crown. These ballets were so effective that their images persist today, and Louis, whose beginnings were so traumatic and filled with uncertainty, is viewed today as the model of the absolute monarchy in European history. These two theorists, Schechner and Goffman, bring to light the cultural as well as political impact of *Le Ballet de la Nuit* and *Nopces de Pelee et de Thetis* in their

entirety – the verse, the costumes, the lighting, the machinery, the décor, the society, and the politics – as events which impacted a variety of social strata.

Chapter 4

CONCLUSION

Image building is not something that only occurred during the Seventeenth Century in the courts of Europe. Even during this century, groups have made use of theatre and performance to present their causes and ideology. Specifically, in the United States, presidential candidates appear in certain settings, wear specific clothing, and utter calculated promises – all of which are designed to affect the American public on a level that creates trust and acceptance. The public image of such candidates is carefully sculpted to attain the greatest association between the candidate and those ideals held in high regard by the general population. Other than politicians, one can find such practices and tools used by athletes, those involved in the entertainment industry, and business professionals who deal with clientele. Even in average, day-to-day interaction with family, friends, associates, and acquaintances, one will use these principles to present oneself in the most affirming light. In everyday interactions, people negotiate their relationships based upon *fronts* and the roles one portrays.

As well as individuals, commercial companies attempt to portray themselves in such a way that the general populous will believe them to be beneficial and necessary. Companies, such as AT&T, General Electric, and Microsoft, spend a great deal of money on advertising that presents them as the good neighbor, the source of humanitarian aid, and as an institution bent on improving the human condition – there to help the community to grow and live in

comfort, rather than trying to make a profit. The commercial company understands that if the battle for the public can be won, then the public will be more likely to spend money at their stores; and carefully calculates how and when to present itself in one way or another.

Beyond mere portrayal and advertising is the next level – propaganda. Social and political institutions use performance as a tool to meet the ends of their regime, party, or administration. Probably the most successful group that used these tactics were the Nazis during their rise to power in the late 1920's and early to mid 1930's. Goebbels in his 1927 speech at the Nuremberg rallies states, "The best propaganda is the most effective... Propaganda does not need to be intellectual; it must be effective. It should express our worldview in a way that can be understood by the masses," (qtd. in Bytwerk). The Nazis understood that propaganda was one of the most effective ways of disseminating information among the people, and that the more closely one's ideas reflected the inner desires of the public – the more likely the public would be to support the leaders of a movement. One, however, doesn't have to be a member of a totalitarian, extremist political group bent on world domination to understand and/or make use of theatre as a tool for the performance of power.

In much the same way as corporations, politicians, and administrations do today, Louis XIV's transformation from powerless youth to "le Soleil levant," the Sun King, was carefully orchestrated and manipulated from beginning to end. Mazarin used the tools of performance, to create in the monarchy an absolute power on earth – God's avatar in Europe. The ballets *Le Ballet de la Nuit* and

Ballet des Noces de Pelee et de Thetis were more than the courtly entertainment, more than a diversionary spectacle to pass the long winter months; but rather, they were tools for inculcating the ideas of the crown into the populace, and unity in a divisive country. Today these techniques are still used, whether it is for a presidential campaign, a commercial media blitz, or the celebration of large political institutions such as NATO. In seventeenth-century France, however, through these ballets an exiled Cardinal effectively molded a young boy into the king that set the standard for Europe for a hundred years – the Sun King.

Works Cited

- Barton, Lucy. Historic Costume for the Stage. Boston: Walter H. Baker Company, 1963.
- Baur-Heinhold, Margarete. The Baroque Theatre: A Cultural History of the 17th and 18th Centuries. New York: McGraw-Hill Book Company, 1967.
- Bramsted, Ernest K. Goebbels and National Socialist Propaganda 1925 – 1945. Michigan State University Press, 1965.
- Brockett, Oscar G with Franklin J. Hildy. History of the Theatre, 8th Ed. Boston: Allyn and Bacon, 1999.
- Buranelli, Vincent. Louis XIV. New York: Twayne Publishers, Inc., 1966.
- Burke, Peter. The Fabrication of Louis XIV. New Haven: Yale University Press, 1992.
- Christout, Marie-Francoise. Le Ballet de Cour au XVII^e Siècle. Genève: Editions Minkoff, 1987.
- Le Ballet de Cour de Louis XIV. Trans. by Alene Long and David Shuhy. Paris: A. and J. Picard, 1967.
- Clarke, Mary. Ballet : an Illustrated History. Rev. ed. London: H. Hamilton, 1992.
- Goffman, Erving. The Presentation of Self in Everyday Life. New York: Doubleday, 1959.
- Hewitt, Barnard, ed. The Renaissance Stage: Serlio, Sabbatini, and Furtenbach. Coral Gables, Florida: University of Miami Press, 1958.
- “German Propaganda Archive.” Calvin College.
<http://www.calvin.edu/academic/cas/gpa/pre1933.htm> . Trans by Randall L. Bytwerk
- Leadbetter, Ron. “Apollo”. [Online] www.pantheon.org/mythica/articles/a/apollo.html
- Lawrenson, T. E. The French Stage in the XVIIth Century. Manchester: Manchester University Press, 1957.
- Mc Kay, John P., Bennett D. Hill, and John Buckler. A History of World Societies. 3rd Ed. Boston: Houghton Mifflin Company, 1992.

- Schechner, Richard. Between Theater and Anthropology. Philadelphia: University of Pennsylvania Press, 1985.
- . Essays on Performance Theory 1970 – 1976. New York: Drama Book Specialists, 1977
- . Performance Theory. New York: Routledge, 1988.
- Siln, Charles I. Benserade and his Ballets de Cour. Baltimore: The Johns Hopkins Press, 1940.
- Strong, Roy. Art and Power: Renaissance Festivals 1450 – 1650. Berkeley: University of California Press, 1984.
- Vince, Ronald W. Renaissance Theatre: A Historiographical Handbook. Westport: Greenwood Press, 1984.

Appendix A

ILLUSTRATIONS



Plate 1

A.1 Louis XIV as Apollo – *Le Ballet de la Nuit* – 1653



Plate 2

A.2. Louis XIV as Apollo – *Noces de Pelee et de Thetis* – 1654

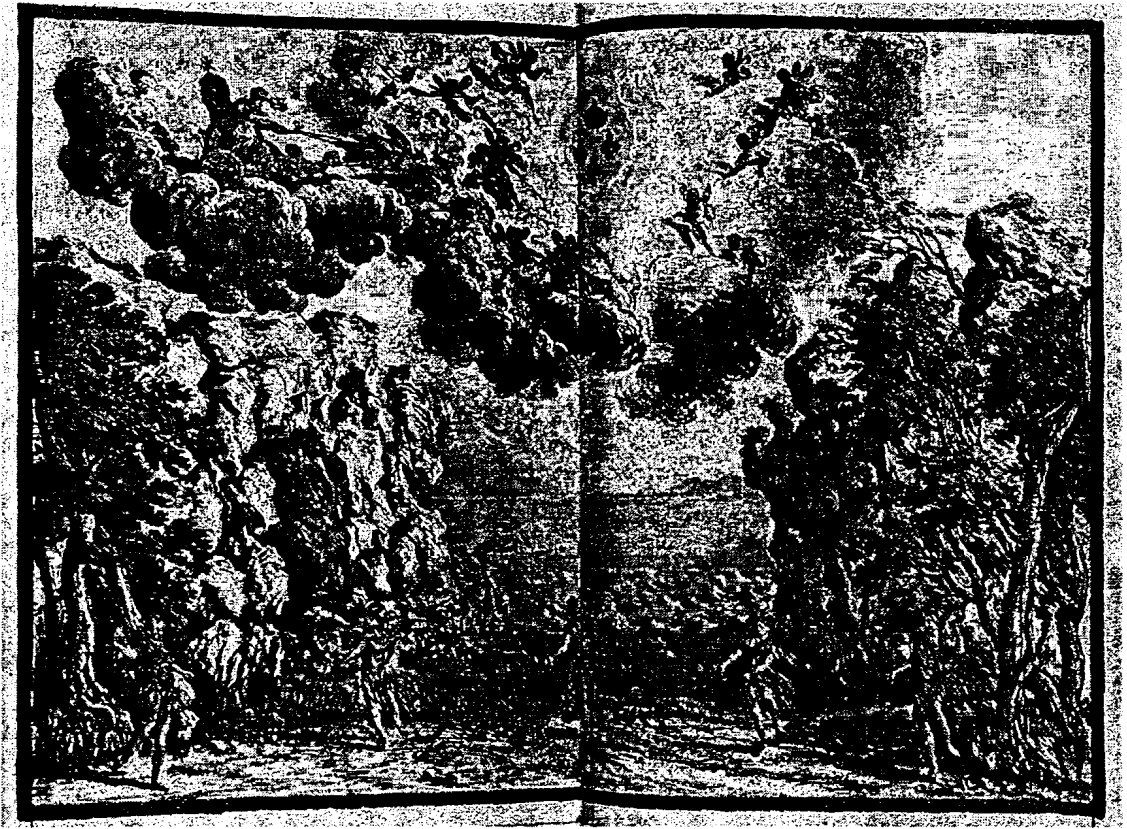

Plate 3

A.3 1st veille – *Le Ballet de la Nuit*
– Entrance of Night



Plate 4

A.4 2nd Veille – *Le Ballet de la Nuit* –
7th entrée



Plate 5

A.5 2nd veille – *Le Ballet de la Nuit* –
The Court of Miracles



Plate 6

A.6 3rd veille – *Le ballet de la Nuit*- 12th
entree



Plate 7

A.7 Act I, scene 3 – *Noces de Pelee et de Thetis* – Jupiter in the clouds

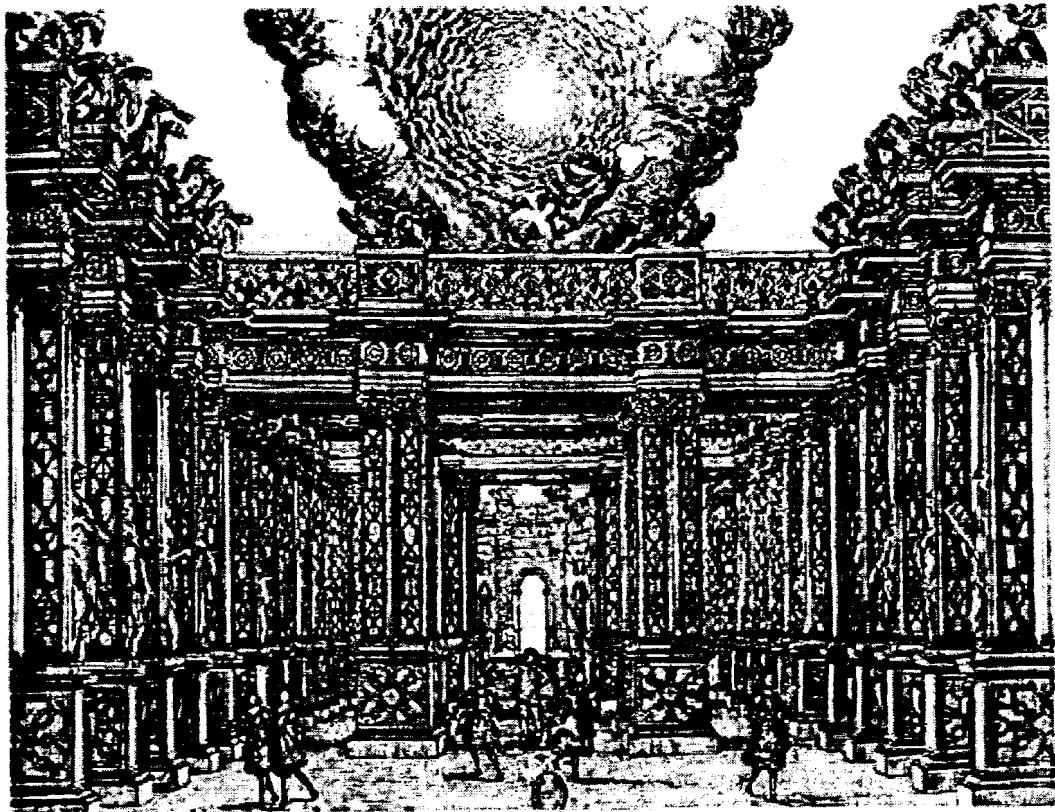

Plate 8

A.8 Act II, scene 2. *Le Noces de Pelee et de Thetis* – The Palace of Jupiter

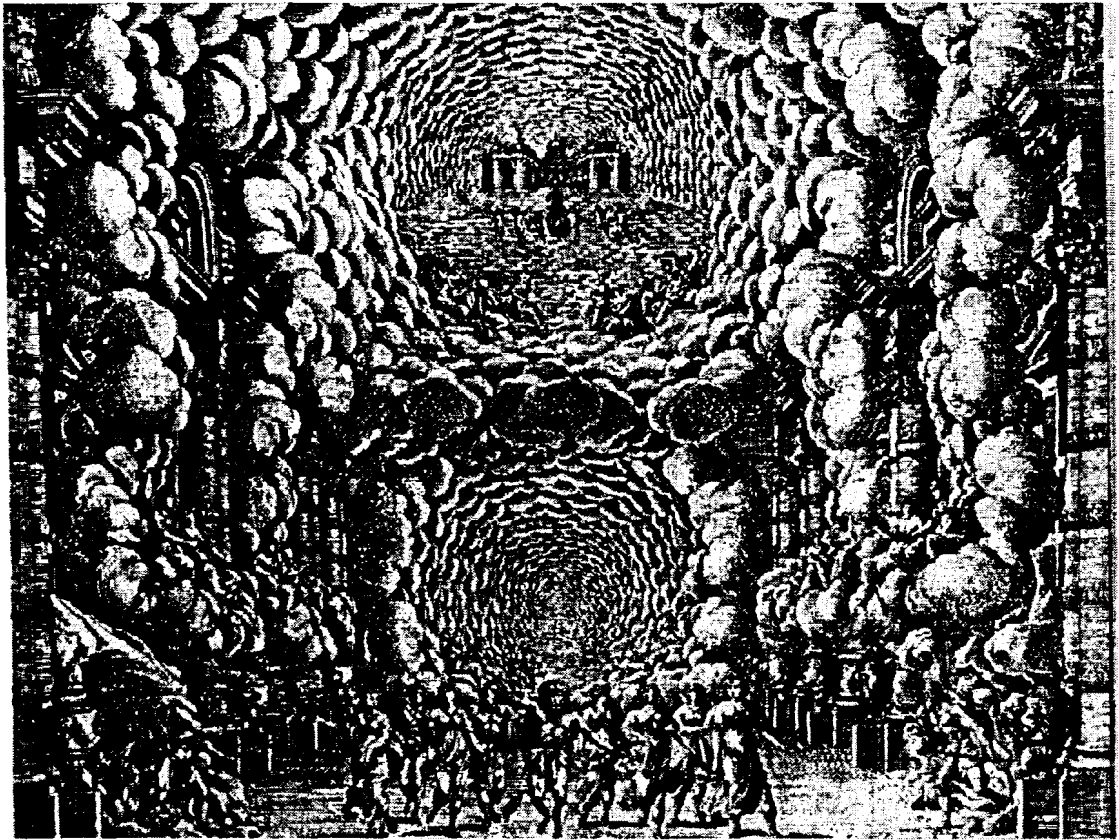

Plate 9

A.9 Act III, scene 2. *Le Noces
de Pelee et de Thetis*



Plate 10

A.10 Sebastian Serlio's Three Scenes

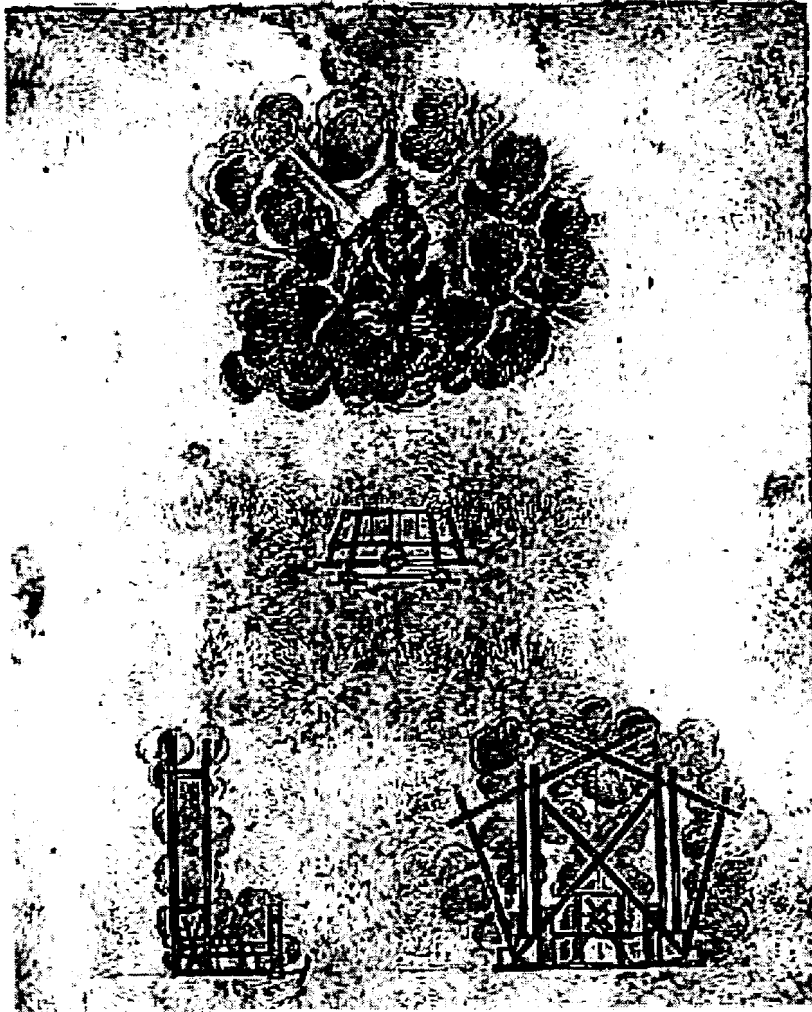

Plate 11

A.11 Design for Flying Machine

*Prima Figura.**Seconda Figura.*

Fig. 62. A CLOUD MACHINE (1638)

Nicolà Sabbatini. Diagram in *Pratica di fabricar scene e machine*.
The clouds F, G, H are shown first grouped together and
then opened out.

Plate 12

A.12 Nicolà Sabbatini's study of a
cloud machine

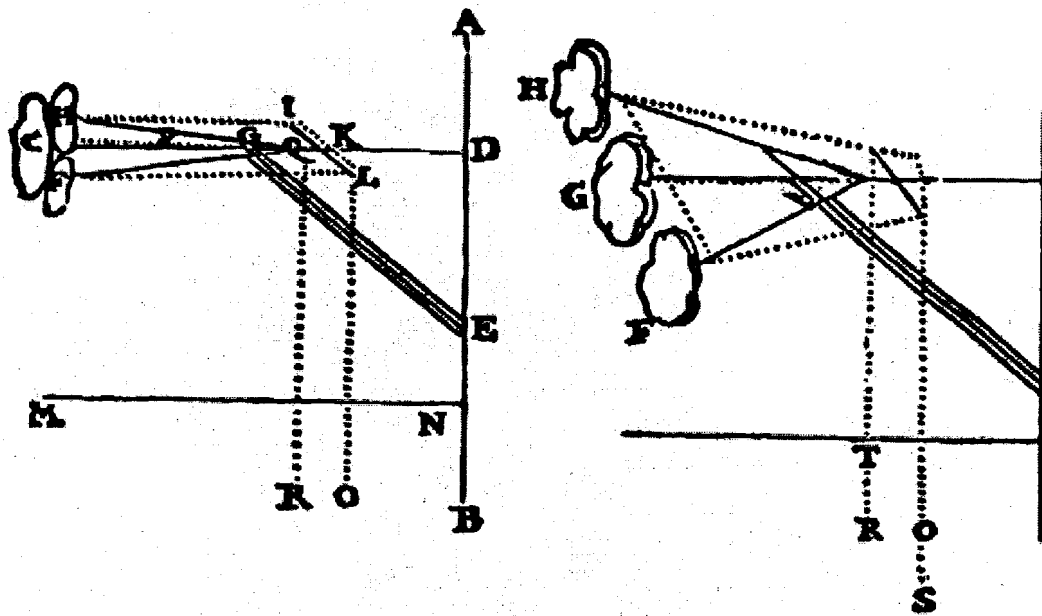
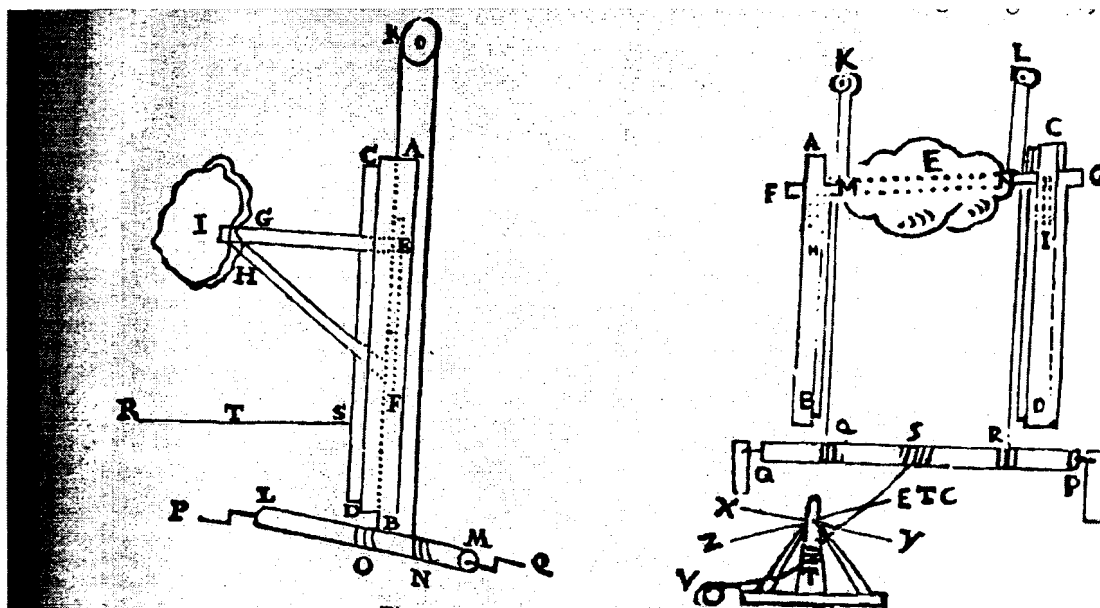

Fig. 27. TWO CLOUD MACHINES (1638)
 Nicolà Sabbatini. Diagrams in *Pratica di fabricar seme e marbino*. The second shows two upright grooves (AB and CD), with a machine supported between them; the first gives only one upright (AB), with the machine set at right angles to the main bar

Plate 13

A.13 Two designs of cloud machines by Nicolà Sabbatini

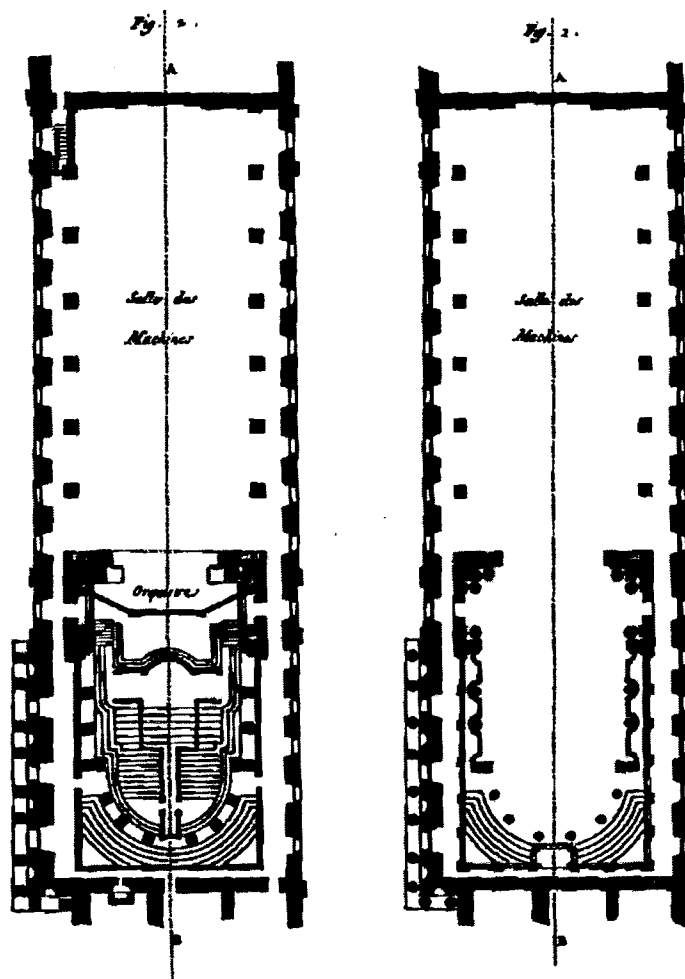

Plate 14

A.14 Le Salle de Machine –
Previously the Petit-Bourbon
Hall

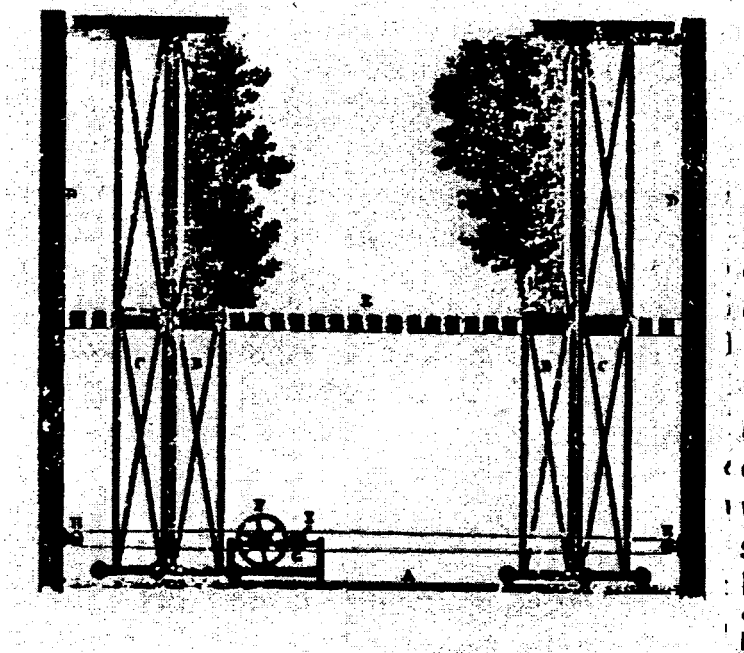

Plate 15

A.15 “Chariot-and-Pole” system of changing scenery.

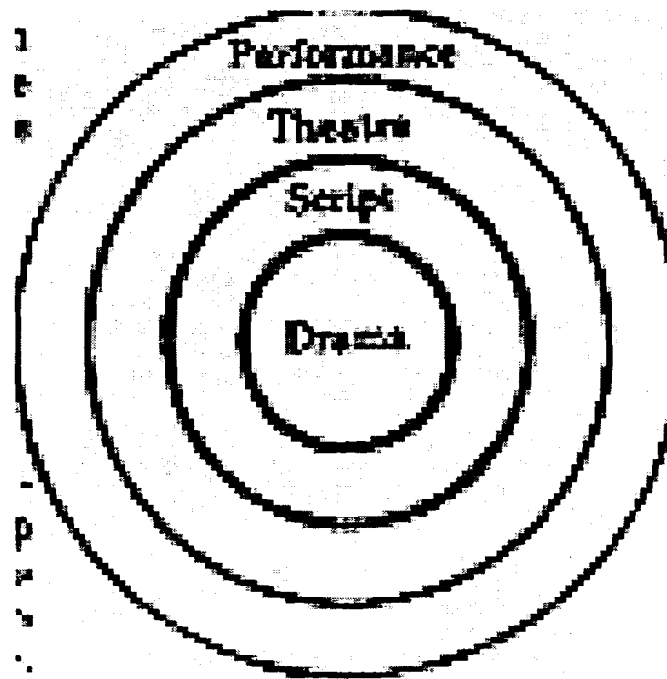

Plate 16

A.16 Schechner's illustration of the relationship between *drama*, *script*, *theatre*, and *performance*.

Appendix B

ORIGINAL FRENCH

Passage 1

“eveillés par le renom du souverain, chantent: *De ce jeune Louis les naissantes merveilles.*” (Christout Le Ballet de Cour de Louis XIV 70).

Passage 2

“en voyant venir le soleil levant incarné par Louis XIV. Le Roi revêt pour la première fois cet aspect, devenu par la suite son emblème le plus cher. Il interprete le grand ballet final accompagné des dénies de l’Honneur, de la Grâce, de l’Amour, de la Valeur, de la Victoire, de la Faveur, de la Renommée, de la Paix... qui viennent lui rendre hommage” (Christout Le Ballet de Cour de Louis XIV 71).

Passage 3

“Le plus mal-place de la salle” (Silin 214)

Passage 4

“Illec on vid des apareils
Qui n’ûrent jamais de pareils,
Le Ciel, l’Air, la Mer et la Terre,

Les Jeux, les Ris, la Pais, la Guerre...
 Maint assaut, maint rude combat,
 Des sorciers allant au sabat,
 Loups-garoux, dragons et chimeres,
 Pluzierurs galans, pluzieurs commeres,
 Des déesses, desforgerons,
 Des chrétiens, des Turcs, des lârons
 Singes, chats, carosse, incendie,
 Foire, bal, balet, comédie;
 On y vid des enchantements,
 Et d'admirables changemens,
 Don't l'incomparable spectacle
 Fit crier cinq cens fois miracle" (Silin 214-5)

Passage 5

"Que de belles et grandes chozes!" (Silin 215)

"Dans ce lieu royal et brilliant" (Silin 216).

Passage 6

"...composé de 43 entrées, toutes si riches, tant par la nouveauté de ce qui s'y
 représente que par la beauté des récits, la magnificence des machines, la pompe
 superbe des habits et la grace de tous les dansuers, que les spectatuerus auroient

difficilement discerné la plus charmante si celles où notre jeune manargue ne se faisoit pas moins connoître sous ses vestemens que le soleil se fait voir au travers des nuages qui voilent quelquefois sa lumière, n'en eussent reçu un caractère particulier d'éclatante majesté, qui en marquoit la différence" (Silin 215).

Passage 7

"M. Clement, qui étoit incomparable en tous ces ouvrages d'esprit, s'y surpassa lui-mesme, et il falloit posséder aussi bien que luy toute la science des festes et des representations, pour imaginer de si belles choses" (Silin 216).

Passage 8

"Le ballet constitue un monde fermé, conventionnel, sensible seulement de façon relative à l'influence de la mode. Dans ce monde de féerie qui possède un vie singulière, la fantaisie se donne libre cours tout en respectant certaines traditions et découvre un pouvoir de fascination semi onirique. Le ballet étant une comédie muette, le costume doit aider le personnage à se faire connaître avant même d'avoir dansé. Selon le désir du Père Ménétrier, il est donc chargé de symboles aussi clairs que possible" (Christout Le Ballet de Cour de Louis XIV 167).

Passage 9

“Sur le plan pratique, les costumes sont extrêmement riches, exécutés en toiles d’or, d’argent, satins, velours, mousselines, et gazes de soie chargées de broderies, d’ornement, d’accessoires découpés en guirlandes, de pierres aux vives couleurs, de perles vraies ou fausses.” (Christout Le Ballet de Cour de Louis XIV 168).

Passage 10

“Les ambassadeurs étrangers qu’on a pris soin de convier auprès du roi d’Angleterre Charles II et de sa mère Henriette de France, admirent certes la délicatesse de la musique, la beauté des entrées de ballet, la variété et la richesse des décors et machines...” (Christout Le Ballet de Cour de Louis XIV 72).

Passage 11

“Jamais d’un plus pompeux théâtre
 L’œil humain ne fut idolâtre,
 Jamais aspects délicieux
 N’enchantaient si bien les yeux,
 Et jamais monseigneur Protée,
 Don’t la fable est partout chantée,
 Ne fit voir en peu de momens
 Tant de merveilleux changemens...” (Silin 233).

Passage 12

“Enfin le spectacle doit une part de son éclat singulier au décorateur et u costumier, c’est-à-dire à Torelli qui, resté fidèle à Mazarin, se surpasse pour affermir enfin sa position longtemps menacée...” (Christout Le Ballet de Cour de Louis XIV 73).

Passage 13

“Se levant, le rideau découvre tout d’abord un paysage boisé encadrant une haute montagne en forme d’arc de triomphe sur laquelle trônent Apollon incarné par le Roi...” (Christout Le Ballet de Cour de Louis XIV 73).

Passage 14

“Plus brillant & mieux fait que tous les Dieux ensemble,
La Terre ni le Ciel n’ont rien qui me ressemble;
De rayons immortels mon front est couronné:
Amoureux des beautés de la seule Victoire
Je cours sans cesse après la Gloire,” (Silin 236).

BIOGRAPHY OF THE AUTHOR

David Shuhy was born in Washington, D.C. on September 12, 1974. He was raised in Ft. Washington, MD and graduated from Grace Brethren Christian School in 1992. He attended Salisbury State University and graduated in 1996 with a Bachelor's degree in Communication Arts. David traveled to Maine to attend the Theatre program at The University of Maine in the Fall of 1999.

Currently David is teaching Theatre and Communication Arts at Salisbury State University. David is a candidate for the Master of Arts degree in Theatre from the University of Maine in December, 2000.